

On controller placement problems in communication networks: preliminary survey. Preprint

Mark Sh. Levin *

Inst. for Information Transmission Problems, Russian Academy of Sciences, Moscow 127051, Russia

The paper addresses controller placement problem in communication networks. A systematic description of the problem domain is presented (i.e., problems, models, solving strategies). Generally, the problem is based on combinatorial optimization models as network clustering and k -center (k -median) models. A traditional solving framework consists of the following stages: (1) definition of the optimal number of controllers, (2) location of the controllers, (3) definition of the controllers types, and (4) design of interconnection network over network elements (i.e., allocation of switches to controllers, design of a network over controllers). Here a special attention is targeted to support combinatorial optimization (CO) problems (e.g., location/assignment, p -center problem, clustering, covering, domination). Some basic optimization formulations (including multi-objective statements) of controller placement problems are described. Illustrations for the considered problems, models and solving schemes are presented.

Keywords: communication systems, controller placement, combinatorial optimization, heuristic, survey

Contents

1	Introduction	2
2	On control in networks	5
2.1	Some recent studies	5
2.2	Illustration of multi-layer network architecture with control	8
2.3	Decentralized control	10
2.4	Literature survey of control/management processes in networks	11
3	On controller placement studies	13
3.1	Recent controller placement and assignment studies	13
3.2	Basic combinatorial approaches for controller placement	15
4	Some basic formulations of controller placement problem	17
4.1	Basic parameters of controller placement problem	17
4.2	Basic criteria/requirement in controller placement problems	17
4.3	Basic description and notations	17
4.4	Two basic formulations of controller placement problem	18
4.5	Two evident bi-criteria models	19
4.6	On multi-criteria models	19
5	Some simple support solving strategies	20
6	Some studies on clustering based controllers placement	21
7	Conclusion	21

1. Introduction

In telecommunication systems infrastructures the subsystem of hierarchical control plays the significant role (e.g., [305]). The paper addresses an network control analysis and controller placement problems. (including study of tree-structured/hierarchical networks). In recent decade, the role of controller placement and assignment problems in contemporary networks has been increased. The controller placement problem in SDNs was proposed in [118]. A simplified scheme of the research is shown in Fig. 1.

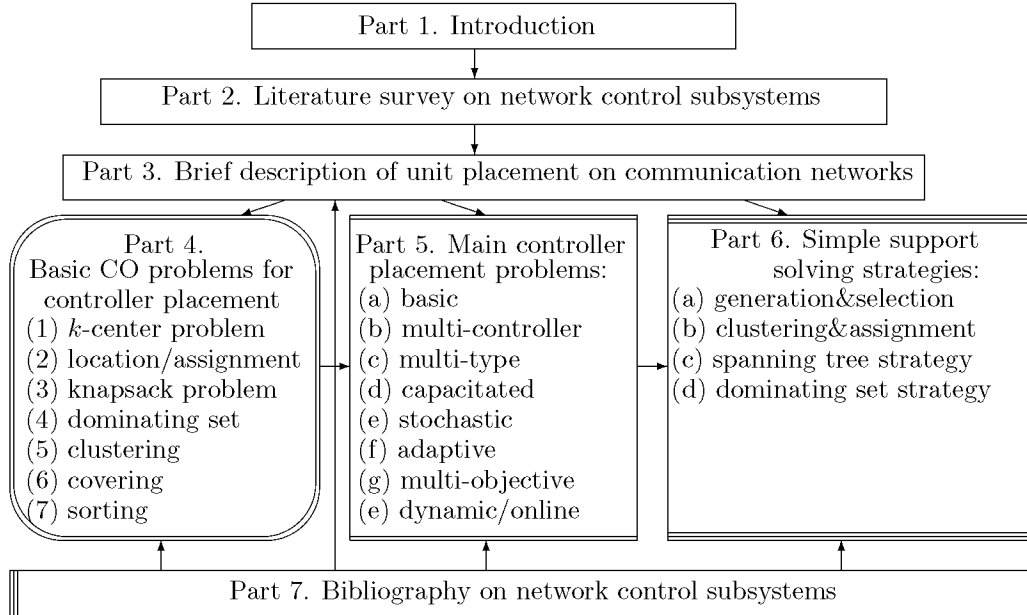

Fig. 1. Simplified scheme of research

A hierarchical illustration of controller location problem is presented in Fig. 2: (i) global controller, (ii) local (domain) controllers, (iii) clusters of nodes (switches). The node clusters above can have intersection(s) and corresponding controllers can have joint domains for the execution of control function(s) (e.g., two clusters at right side in Fig. 2). Usually two layers are considered (e.g., [11,77,167,170,266]): control plane (controllers), data plane (switches/nodes).

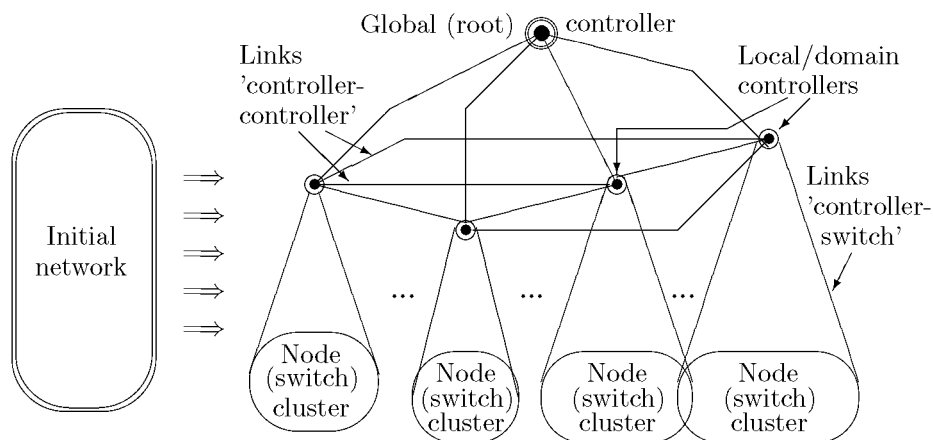

Fig. 2. Illustration for controller location problem

The controller placement problem is targeted to minimization of the cost of the network (e.g., minimization of the propagation latency, minimum control latency) while taking into account a set of constraints. The following factors are usually examined in the controller placement problems (e.g., [85,141,176,196,355]):

1. The latency of control signaling. The switches receive the instructions on how to forward the new flows. Whenever the latency between controllers and switches reaches a threshold, the latency on the whole network will increase substantially. In this case, the controller processing latency is a non-negligible factor in the total round-trip latency [277].

2. The server capacity limitation. Due to the constraints of the resources such as processors, memory, and access bandwidth, a commodity server only has the capacity to manage a limited number of switches. On the other hand, the overload of controllers may decrease the performance of SDN [355].

3. The required number of controllers. In large-scale SDN networks, a large amount of switches in data plane construct a complex networks. It is difficult for administrators to figure out how many controllers should be deployed. Some work uses the traversal searching method to iteratively find the best performance number, which may lead to high time consumption [44].

4. Fault tolerance. Unlike the traditional network architecture, the switches do not have control ability due to the split architecture of SDN. Each switch is assigned a controller. Therefore whenever a switch loses the connection to its controller, it will no longer receive any new routing instructions and thus drop all packets [368].

5. Inter-controller communication. In multi-controller SDNs, each switch is controlled by a specific controller. If a controller wants to send messages to a switch controlled by another controller, the controllers need to communicate with each other [80].

Therefore, the inter-controller communication affects the performance in end-to-end communication between disparate switches controlled by different controllers.

A traditional solving framework of the controller placement in communication networks consists of the following stages: (1) definition of the optimal number of controllers, (2) location of the controllers, (3) definition of the controllers types, and (4) design of interconnection network over network elements (i.e., allocation of switches to controllers, design of a network over controllers).

In general, the controller placement problem is considered as follows (e.g., [359]). The following is given: $G = (V, E, S)$, where V is the controller set, E is the switch set, S is the link set. The problem formulation is:

Find the number of controllers $n = |V|$, and the mapping $V \rightarrow S$ in the network (i.e., location of the controllers in the network).

A scheme of combinatorial optimization based approaches and controller placement problems is depicted in Fig. 3.

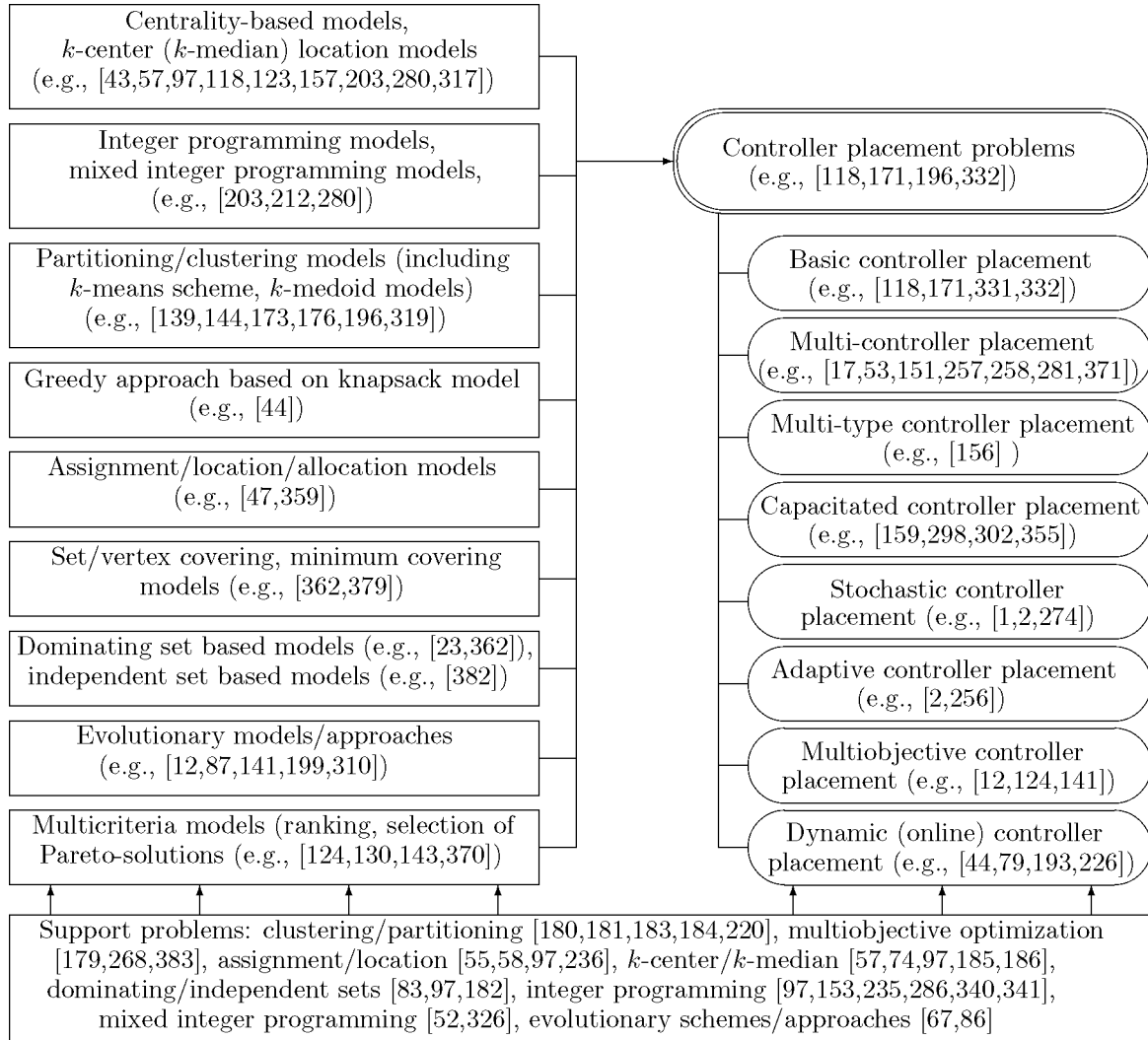

Fig. 3. Scheme: combinatorial optimization and controller placement

In the paper, a survey on controller placement problems in communication networks is presented.

2. On control in networks

2.1. Some recent studies

In recent years, the significance of distributed control/monitoring in networked systems has been increased. Here the problems of location/placement of control (monitoring, measurement, aggregation) units have a crucial central role. An illustrative scheme for the problem domain is presented in Fig. 4.

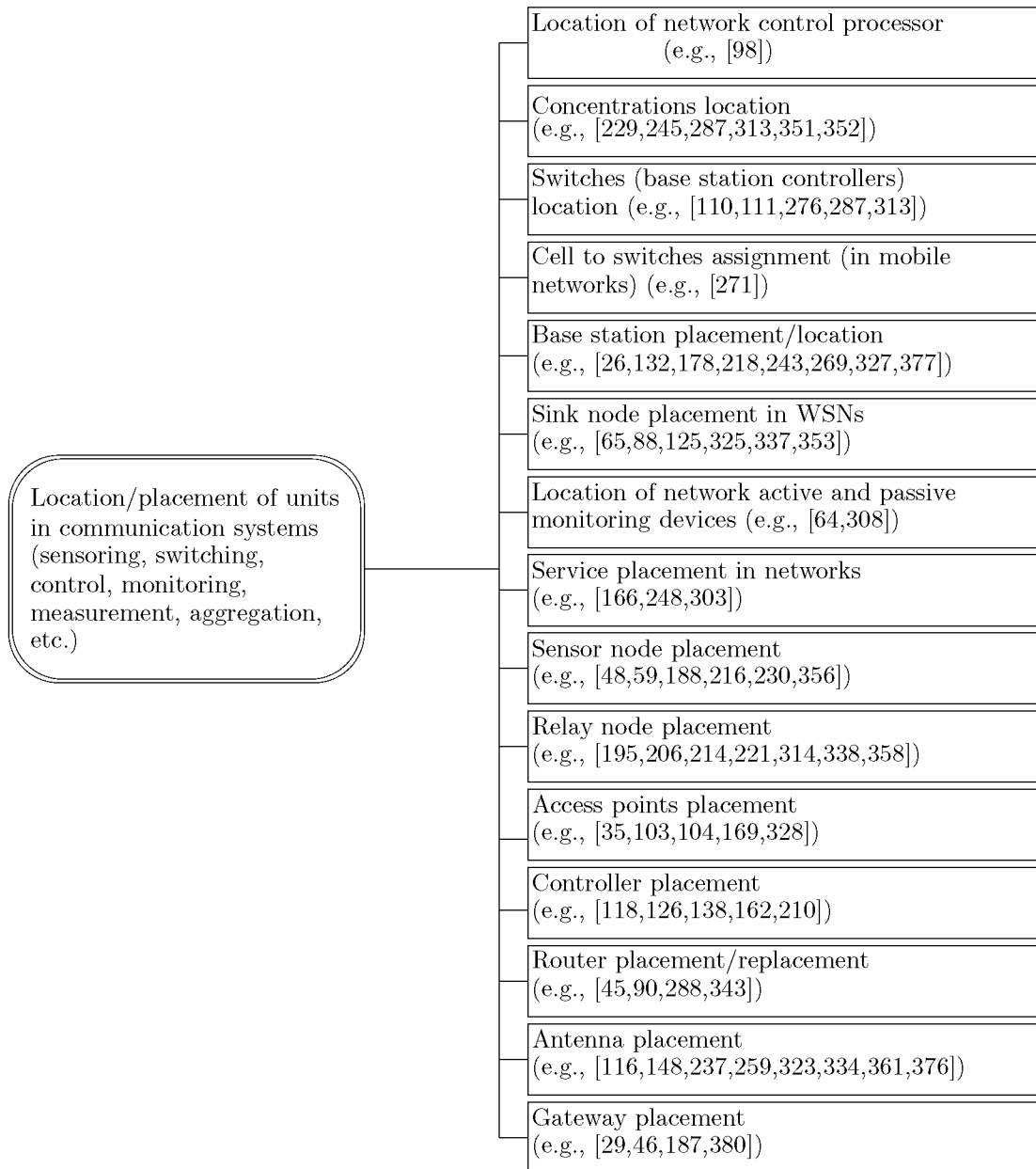

Fig. 4. Placement of network units (e.g., control, monitoring, access, integration)

Note, multi-controllers architecture are widely used in software defined networks (e.g., [129,213,254,306,371]).

Some recent studies of control/management processes in networks are listed in Table 1.

Table 1. Some recent studies of control/management processes in networks, part 1

No.	Some studies of control issues in networks	Source(s)
1.	Surveys:	
1.1.	Networked control systems (survey, recent progress)	[345]
1.2.	Cyber-physical control over wireless sensor and actuator networks	[344]
1.3.	Dynamic key management algorithms in WSNs (survey)	[357]
1.4.	Networked control systems (survey of trends and techniques, including “control over networks”)	[375]
1.5.	Survey on networked control systems (multi-hop channels)	[60,121]
1.6.	Coverage control in sensor networks	[330]
1.7.	Distributed SDN control (survey, taxonomy, challenges, architectural issues)	[41]
1.8.	Distributed SDN controller system (survey on design choice)	[233]
1.9.	Autonomic network management (current and future research directions)	[278]
1.10.	Multi-controller deployment in SDN-enabled 6G space-air-ground integrated network (including five-layer architecture)	[198]
1.11.	Controller placement problem during SDN deployment in ISP/Telco networks (survey)	[282]
1.12.	Real-time and reliable industrial control over wireless LANs (algorithms, protocols, and future directions)	[322]
1.13.	Survey on controller placement strategies	[138]
1.14.	Survey on controller placement in SDNs	[72]
2.	Architectural issues:	
2.1.	Architectures for networked control systems	[102]
2.2.	Multi-layer architecture for controllers in networks (Industry 4.0)	[366]
2.3.	Network management architecture for hybrid SDN	[279]
2.4.	Design of controller for mobile robots (modularized control architecture)	[172]
2.5.	Architecture, implementation and evaluation of join and spilt TCP for SDN networks (dynamic controlling)	[109]
2.6.	Multiple controllers architecture (in SDN, load-balancing strategy)	[346]
2.7.	Elastic distributed SDN controller architecture	[80]
2.8.	Agent-based control architectures for next generation telecommunication network infrastructures	[120]
2.9.	SDN based routing architecture for wireless mesh networks (including control plane, data plane)	[100]
2.10.	Controller-based roadside unit plane architecture (for software-defined internet of vehicles)	[215]
2.11.	Multi-level hierarchical control plane architecture in SDN	[264]
2.12.	Architecture of combination: SDN and IoT	[295]
3.	Control schemes in communication networks:	
3.1.	Centrally controlled wireless data networks	[307]
3.2.	Centrally controlled networks (adaptive computation framework)	[211]
3.3.	Energy efficient coverage control in WSNs (multi-objective genetic algorithm)	[150]
3.4.	Power control in distributed underwater wireless sensor networks (UWSN) (cooperative game)	[348]
3.5.	Distributed power control (for the downlink of multi-cell NOMA systems)	[94]
3.6.	Networked control systems with communication constraints	[30,117]
3.7.	Edge-based platoon control (including control topology)	[255]
3.8.	Optimization of the quality control station configuration	[239,240]
3.9.	Hierarchical control in sociotechnical systems	[200]
3.10.	Coverage control for mobile sensing networks	[69]
3.11.	Industrial wireless networked control systems (reliable fault tolerant-based multipath routing model)	[4]
3.12.	Power control in HetNets	[39,122,165]
3.13.	Energy aware resource control mechanism in green 6G networks	[312]
3.14.	Distributed and throughput optimal power control in wireless networks	[51]

Table 1. Some recent studies of control/management processes in networks, part 2

No.	Some studies of control issues in networks	Source(s)
4.	Control issues in software defined networks (SDNs):	
4.1.	Cross-layer access control (over SDNs)	[374]
4.2.	Network management with software defined networking	[164]
4.3.	Network management architecture for hybrid SDN	[279]
4.4.	Evaluation, performance analysis of SDN/OpenFlow network controllers	[49,291]
4.5.	Control mechanism of cloud computing (using SDN)	[231,246]
4.6.	Distributed SDN control (survey, taxonomy, challenges, architectural issues)	[41]
4.7.	Distributed SDN controller system (survey on design choice)	[233]
4.8.	Control plane of SDNs (survey)	[347]
4.9.	Distributed SDN controllers for distributed IoT	[93]
4.10.	Controller placement in multi-control 5G based on SDN/NFV architecture	[135]
4.11.	Multi-controller SDN architecture	[175,306,365]
4.12.	Survey of diverse SDN controllers, multiple SDN controllers	[11]
4.13.	Prioritized admission control with load distribution over multiple controllers for scalable SDN-based mobile networks	[175]
5.	Controller placement issues:	
5.1.	Controller placement problems	[118,171,331,332]
5.2.	Problem of placing monitoring devices as total domination in graphs	[119]
5.3.	Multicriteria controller placement problems in software defined networks	[124,143,144]
5.4.	Reliable/resilient control placement in software defined networks	[108,124,144,145,242]
5.5.	Placement of controllers in software-defined WAN (meta-heuristic)	[273]
5.6.	Controller placement for designing a distributed SDN control layer	[152]
5.7.	Capacitated controller placement problem in SDNs	[302,321,355]
5.8.	Optimizing controller placement for SDNs	[131]
5.9.	Traffic-aware dynamic controller assignment in SDN (stable matching)	[47]
5.10.	Traffic-aware dynamic controller placement using AI in SDN-based aeronautical networks	[212]
5.11.	Controller placement optimization in hierarchical distributed SDN in VANET	[203]
5.12.	Clustering for controller placement (e.g., in SDN)	[25,54,196]
5.13.	Controller placement strategies	[138]
5.14.	Controller placement issues in SDNs with different goals (survey)	[225]
5.15.	Taxonomy of controller placement problem (CPP) optimization in SDN	[294]
5.16.	Survey on controller placement in SDNs	[72]
5.17.	Dynamic controller deployment for Low Earth Orbit satellite networks (multi-objective model, objectives: minimization of controller-switch delay, maximization of network reliability)	[79]
6.	Multiple controller systems (multiple controller placement):	
6.1.	Multiple controller environments (e.g., in SDNs)	[17,129,174,254,258,371]
6.2.	Multi-controller based software-defined networking (survey)	[129]
6.3.	Survey on software defined networking with multiple controllers	[371]
6.4.	SDN architectures with multiple controllers	[53,175,365,371]
6.5.	Multi-controller placement for load balancing in software-defined wide area network (SDWAN)	[354]
6.6.	Load-balancing multiple controllers mechanism for SDN	[213,283]
6.7.	Machine intelligence approach for load balancing in multi-controller based SDN	[306]

Table 1. Some recent studies of control/management processes in networks, part 3

No.	Some studies of control issues in networks	Source(s)
7.	Scheduling issues in control systems:	
7.1.	Scheduling of networked control systems	[329]
7.2.	Scheduling in sensor node and controller node for wireless networked control systems	[315]
7.3.	Controlled service scheduling scheme for user-centric SDN-based IoT	[19]
8.	Some special studies:	
8.1.	Co-design of Safe Networked Control Systems	[284]
8.2.	Wireless LAN transmitter location under the threat of jamming attacks (optimal location)	[285]
8.3.	Stability of networked control systems	[28,81,367]
8.4.	Power control in heterogeneous ultra-dense networks	[202]
8.5.	Supervisory control synthesis (in model-based systems engineering)	[37]
8.6.	Cooperative controllers (for highway)	[241]
8.7.	Hybrid control design for linear networked systems	[34]
8.8.	Controllers for stochastic systems	[274]
8.9.	Controller area networks	[99,107,373]
8.10.	Traffic control/management in communications	[219]
8.11.	Optimal control for networked control systems with Markovian packet losses	[115]
8.12.	Rate control algorithms	[289]
8.13.	Control policies for energy-efficient remote health monitoring (wireless body area network)	[42]
8.14.	Taxonomy of node placement approaches in sensor networks (relay nodes, controllers, sink nodes)	[88]
8.15.	Review of the control plane scalability in software defined networking	[6]
8.16.	Multiobjective robust controller synthesis approach	[36]

2.2. Illustration of multi-layer network architecture with control

The basic versions of topological control paradigms are shown in Fig. 5. (e.g., [76]).

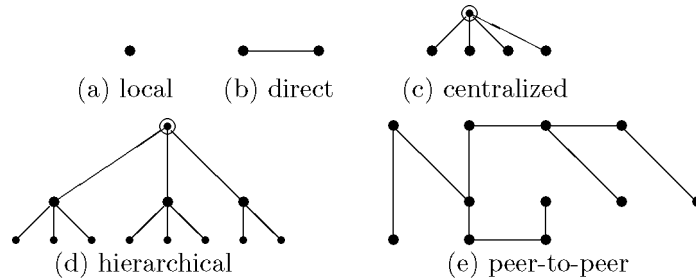

Fig. 5. Control paradigms for local and coordinated control

Further here some illustration examples of multi-layer (hierarchical) network architecture with control layers/units are presented. In Fig. 6, a simplified multi-layer architecture of SDNs with a control layer is shown (e.g., [11,49,77,78,170,266]).

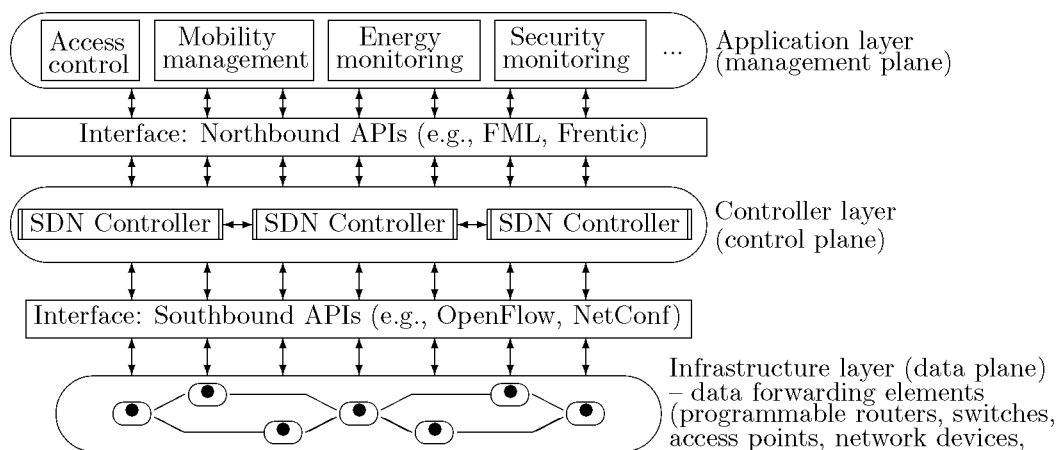

Fig. 6. Simplified multi-layer architecture of SDNs

An illustration of SDN-based IoT architecture is depicted in Fig. 7 (e.g., [295]).

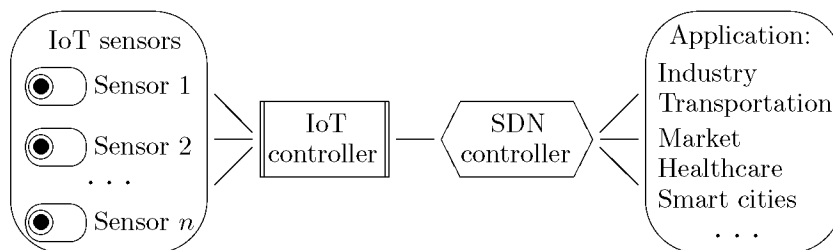

Fig. 7. Simplified SDN-IoT architecture

An illustrative example of hierarchical network control in SDN assisted ON (opportunistic network) architecture is described in [73,342] (Fig. 8).

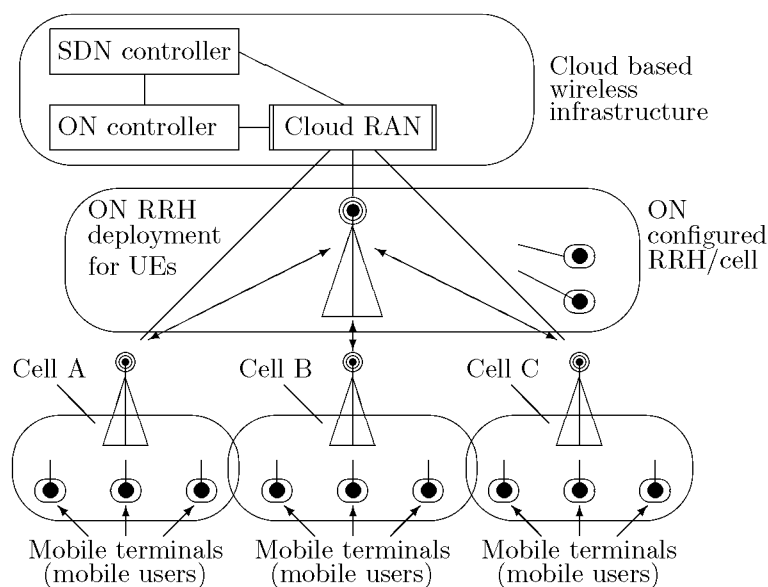

Fig. 8. SDN assisted ON architecture (hierarchical control)

A simplified scheme of SDN-IoT integration (including a control part) is depicted in Fig. 9 (e.g., [93]).

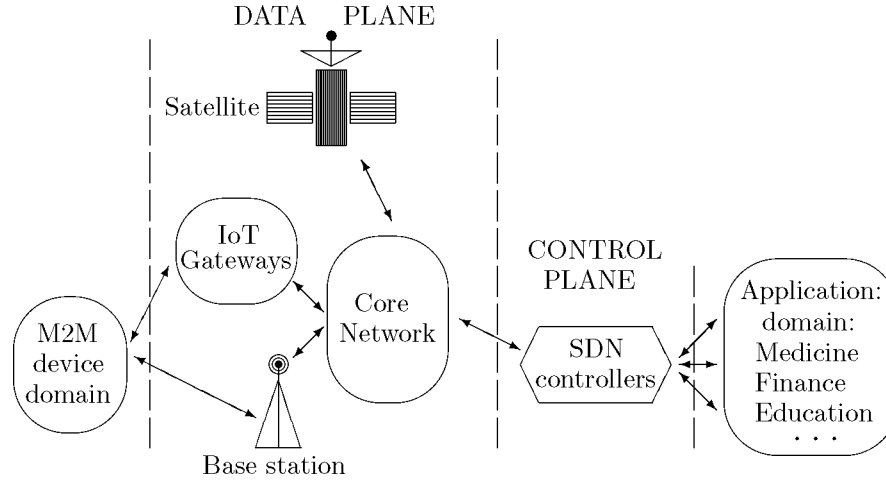

Fig. 9. Simplified scheme of SDN-IoT integration

2.3. Decentralized control

Decentralization of control in hierarchical systems plays an important role in many research domains [105]: economics, management, decision making, mathematical modeling, engineering, operations research (mathematical programming).

Some studies on distributed (decentralized) control/management processes in networks are pointed out in Table 2.

Table 2. Some recent studies of distributed control-management in networks

No.	Studies of distributed control-management in networks	Source(s)
1.	Control decentralization in hierarchical systems	[105]
2.	Distributed coordination control of traffic network flow	[372]
3.	Distributed flow management in SDNs	[50]
4.	Design of robust controllers on the grid (multiobjective evolutionary approach)	[293]
5.	Coordinated session-based admission control with statistical learning for multi-tier internet applications	[228]
6.	Replica server placement algorithms for content delivery networks (placement models)	[272]
7.	Optimal placing of the information-technological reserve (ITR) in distributed data processing systems (i.e., placement of the ITR copies in computer networks) (p -median models)	[304]
8.	Design and simulation of a mobile radio network with distributed control	[38]
9.	Merging control in networks (multi-agent systems)	[113]
10.	Design of hierarchical decentralized controllers to guarantee the structural stability of chemical plants	[84]
11.	Adaptive load balancing scheme for SDN controllers (distribution of traffic load in the controllers)	[250]
12.	Top-down approach to distributed control of discrete-event systems	[56]
13.	Distributed SDN controllers in distributed IoT	[93]
14.	Hierarchical controllers in internet of vehicles	[217]

2.4. Literature survey of control/management processes in networks

Table 3 contains a list of some recent studies of control/management processes in networks.

Table 3. Some recent studies of control/management processes in networks (combinatorial models), part 2

No.	Some studies of control issues in networks	Source(s)
3.	Dynamic control/management:	
3.1.	Dynamic controlling in networks (SDN)	[109]
3.2.	Dynamic bandwidth management in single-hop ad hoc wireless networks	[290]
3.3.	Switched dynamics	[75]
3.4.	Issues of mobility management in networks	[101,238]
3.5.	Dynamic traffic control expert system	[339]
3.6.	Supervisory controller design in timed-transition Petri nets	[33]
3.7.	Dynamic power management in cluster system (Markov decision process)	[232]
3.8.	Resource controller problem in networks	[9]
3.9.	Controller and estimator for dynamic networks	[168]
3.10.	Dynamic channel allocation for efficient power management (control) in multi-channel IEEE 802.16 networks (WiMAX)	[27]
3.11.	Optimal sensor placement for target tracking	[216]
4.	Topology control/management in networks:	
4.1.	Topology control in WSNs:	
4.1.1.	Topology control for WSNs	[63,147,261]
4.1.2.	Topology control for two-tiered WSNs	[177]
4.1.3.	Topology management in large and dense real-time WSNs	[208]
4.1.4.	Topology control for two-tier wireless sensor networks	[234]
4.2.	Topology control in Ad Hoc Networks:	
4.2.1.	Topology control problems for Ad Hoc networks (algorithmic aspects)	[70,205]
4.2.2.	Topology control and routing in Ad Hoc networks	[260]
4.3.	Distributed topology control techniques for low interference and energy efficiency in WSNs	[68]
4.5.	Probabilistic and highly efficient topology control algorithms	[189,190]
4.5.	Largest connected-topology minimum interference topology control problem (in cognitive radio networks)	[349]
4.7.	Topology control for dynamic clusters in MANET	[262]
4.10.	Topology control for WSNs (virtual backbone)	[333]
5.	Cluster-based control/management:	
5.1.	Cluster-based control channel allocation in opportunistic cognitive radio networks (spectrum opportunity clustering design, maximum edge biclique model)	[201]
5.2.	Cluster control of heterogeneous thermostatically controlled loads using tracer limits	[133]
5.3.	Clustering scheme for hierarchical control in multi-hop wireless networks	[40]
5.4.	k -hop clustering scheme for the optimal common control channel assignment problem (cognitive radio networks)	[350]

Table 3. Some recent studies of control/management processes in networks (combinatorial models), part 3

No.	Some studies of control issues in networks	Source(s)
6.	Some control issues in contemporary networks:	
6.1.	Access control for IoT networks	[96]
6.2.	Common control channel design in cognitive radio networks (clustering, biclique model, balancing)	[207]
6.3.	Delay gradient based congestion control for IoT	[265]
6.4.	Distributed flow management in SDNs	[50]
6.5.	Power management in virtualized datacenter (power management, server heterogeneity controls, server virtualization controls, etc)	[222]
6.6.	Dynamic controlling in networks (SDN)	[109]
6.7.	Multi-layer architecture for controllers in networks (Industry 4.0)	[366]
6.8.	Power control (e.g., for connected vehicles)	[106]
6.9.	Performance analysis of SDN/OpenFlow controllers	[49]
6.10.	Load-balancing multiple controllers mechanism for software-defined networking multiple controller environment with hierarchical control plane	[213]
6.11.	Controller design for data center network	[318]
6.12.	Energy-efficient management techniques in cloud data centers (DCs), current challenges: static management, dynamic management (for hardware level, for virtualization/software level)	[112]
6.15.	Hierarchical SDN controllers with adaptive offload	[292]
6.16.	Coverage control of sensor networks in IoT	[336]
6.17.	Distributed SDN controllers in distributed IoT (edge computing, federated learning)	[93]
7.	Virtual machine placement problems:	
7.1.	Efficient resource allocation as virtual machine placement	[15]
7.2.	Secure virtual machine placement in cloud data centers	[10]
7.3.	Optimistic virtual machine placement in cloud data centers (queuing approach)	[247]
7.4.	Energy-efficient dynamic Virtual Machine Placement in data centers	[21]
7.5.	Virtual machine placement in data center networks (minimizing connection cost)	[95]
7.6.	Virtual machine placement (multi-objective reinforcement learning)	[253]
7.7.	Virtual machine placement in cloud computing (imperialist competitive algorithm)	[146]
7.8.	Virtual machine consolidated placement (multiobjective biogeography-based optimization)	[378]
7.9.	Virtual machine placement in cloud computing (chemical reaction optimization)	[191]
7.10.	Virtual machine placement and migration in cloud environments (optimization, survey)	[91]
7.11.	Multi-objective communication-aware optimization for virtual machine placement in cloud datacenters	[89]
7.12.	Predictive Anti-Correlated Placement Algorithm (PACPA) for VM placement (cloud data centers)	[134]
7.13.	Optimizing virtual machine placement for energy and SLA in clouds (using utility functions)	[227]
7.14.	Hybrid energy-aware virtual machine placement algorithm for cloud environments	[5]
7.15.	Survey on the use of preferences for virtual machine placement in cloud data centers	[18]
8.	Virtual network function (VNF) placement in networks:	
8.1.	VNF and CHF placement in 5G (recent advances, future trends)	[31]
8.2.	Efficient VNF placement in network function virtualization	[251]
8.3.	User mobility-aware VNF placement for virtual 5G network infrastructure	[311]
8.4.	Combining deep reinforcement learning with graph neural networks for optimal VNF placement	[309]
8.5.	VNFs placement and routing optimization	[7]
8.6.	Survey on wireless SDNs (W-SDNs) and network function virtualization (NFV) for 5G cellular systems	[16]

3. On controller placement studies

3.1. Recent controller placement and assignment studies

Some recent controller placement and assignment studies are listed in Table 4.

Table 4. Some recent controller placement and assignment studies, part 1

No.	Controller placement and assignment study	Source(s)
1.	Basic problems, surveys:	
1.1.	Basic controller placement problem	[118,171,331]
1.2.	Controller placement problems in software defined networking (surveys)	[126,174,210] [296,332]
1.3.	Controller placement in SDNs (comprehensive surveys)	[162]
1.4.	Taxonomy of controller placement problem (CPP) optimization in SDN	[294]
1.5.	Min-cover based controller placement approach (for reliable control network in SDN)	[379]
1.6.	Distributed controller placement in SDN	[137,197,362,369]
1.7.	Survey on SDN controller placement strategies	[138]
1.8.	SDN architectures with multiple controllers	[53]
1.9.	Robust controller placement for link failure in SDNs (Pareto-efficient solutions)	[130]
1.10.	Controller placement issues in SDNs with different goals (comprehensive survey)	[225]
1.11.	Survey of controller placement problem in SDN-IoT network	[3]
1.12.	Optimizing SDN controller to switch latency for controller placement problem	[382]
1.13.	Review and future directions on controller placement in software defined emerging SDNs (including satellite communication networks)	[71]
2.	Contemporary problems:	
2.1.	Optimal models for the controller placement problem in SDNs	[114,131,277]
2.2.	Reliability-aware controller placement for SDNs	[267]
2.3.	Energy-aware controller placement problem in SDNs	[128]
2.4.	Load balanced controller placement problem in SDNs	[127]
2.5.	Controller placement problem for wireless SDN	[85]
2.6.	SDN-controller placement for D2D communications	[204]
2.7.	Reliable control placement in SDNs	[144,145]
2.8.	Controller placement optimization in hierarchical distributed software defined vehicular networks	[203]
2.9.	Cost-effective controller placement in software-defined multihop wireless networking (deep reinforcement learning)	[364]
2.10.	Hierarchical controllers in internet of vehicles model	[217]
2.11.	Multi-controller placement in software-defined networking	[258]
3.	Capacitated controller placement problems:	
3.1.	Capacitated SDN controller placement problem	[301]
3.2.	Capacitated controller placement problem in SDNs	[355]
3.3.	Capacity and load aware SDN controller placement in heterogeneous environments	[156]
3.4.	Control plane delay minimization-based capacitated controller placement algorithm for SDN	[61]
3.5.	Capacity-aware and delay-guaranteed resilient controller placement for software-defined WANs	[316]
3.6.	Network cost optimization-based capacitated controller deployment for SDN	[62]
4.	Controller placement in large scale networks:	
4.1.	Controller placement problem in large scale SDNs	[176,196]
4.2.	Controller placement in software defined wide area networks	[335]
4.3.	Density cluster based approach for controller placement in large-scale SDNs	[196]
4.4.	Optimal controller placement in large scale SDNs software (based on modified NSGA-II)	[142]
4.5.	Controller placement in large-scale SDN (parameter optimization, heuristics, PSO)	[192]

Table 4. Some recent controller placement and assignment studies, part 2

No.	Controller placement and assignment study	Source(s)
5.	Dynamic controller placement/assignment studies:	
5.1.	Controller placement in multi-control 5G based on SDN/NFV architecture (dynamic capacitated controller placement problem)	[135]
5.2.	Dynamic controller assignment in software defined internet of vehicles (through multi-agent deep reinforcement learning)	[360]
5.3.	Dynamic controller assignment in LEO satellite based SDN (using multi-agent deep reinforcement learning)	[226]
5.4.	Dynamic assignment of software-defined controllers in vehicle networks an evolutionary game approach	[149]
5.5.	Dynamic controller provisioning in SDNs	[44]
6.	Multiobjective (multicriteria) controller placement problems:	
6.1.	Survey of multiobjective controller placement problems in SDNs	[174]
6.2.	Multicriteria controller placement problems in SDNs	[143,144]
6.3.	Pareto-optimal resilient controller placement in SDN-based core networks	[124]
6.4.	Multiobjective controller placement in SDNs (genetic algorithms)	[12,141]
6.5.	MCDM scheme (Analytical Network Process) for controller placement	[22]
6.6.	Multiple criteria analysis of controller placement problem in SDNs (AHP technique)	[143]
6.7.	Multi-objective optimization controller placement problem in Internet-oriented SDNs	[370]
6.8.	Multiobjective controller placement in SDNs (adaptive heuristic)	[13]
6.9.	Optimal controller placement in large scale SDNs software (multicriteria combinatorial optimization model)	[142]
6.10.	Multi-objective controller placements for latency minimization of both primary and backup paths in SDNs (evolutionary approach)	[87]
6.11.	Multi-objective placement of SDN controllers (optimization of cost and network performance in WSNs)	[310]
7.	Controller placement problems under uncertainty:	
7.1.	Stochastic controller placement problems in wireless/cellular SDNs	[1,2]
7.2.	Robust controller placement and assignment in SDNs (stochastic problem)	[2]
7.3.	Failure-based controller placement in SDNs (decision under uncertainty)	[244]
8.	Special controller placement studies:	
8.1.	Controller placement problem for robust SDNs	[280]
8.2.	Adaptive controller placement (for wireless sensor-actuator networks)	[256]
8.3.	Inter-controller consensus in the placement of distributed SDN controllers	[369]
8.4.	Elastic distribution of SDN/NFV controllers (for 5G cloud management systems)	[14,80]
8.5.	Improving resilience of controller placement with minimum backup capacity in SDNs	[161]
8.6.	SDN controller placement with delay-overhead balancing in wireless edge networks	[252]
8.7.	Flow processing-aware controller placement in wireless DenseNets	[32]
8.8.	QoS-Guaranteed controller placement in SDN (e.g., delay minimization)	[66,381]
8.9.	Exploring the impact of critical programmability on controller placement for software-defined wide area networks	[82]
8.10.	Controller placement in SDN using game theory and discrete hybrid metaheuristic algorithm	[155]
8.11.	Survival backup strategy for controller placement in SDNs	[24]
8.12.	Comparative analysis of SDN controller placement problem (IoT-specific tactics and generalized solutions)	[324]

3.2. Basic combinatorial approaches for controller placement

Table 5 contains a list of basic solving approaches for controller placement problems.

Table 5. Basic solving approaches for controller placement problems, part 1

No.	Method	Source(s)
1.	Basic solving methods:	
1.1.	Min-cover based controller placement approach	[379]
1.2.	K -means-based network partitioning algorithm	[331]
1.3.	Density cluster based approach	[196]
1.4.	Heuristic approaches (e.g., partitioning based)	[176]
1.6.	Centrality based algorithms for controller placements (in software defined wide area networks)	[8]
1.7.	Betweenness centrality & hierarchical clustering for distributed SDN controller placement	[20]
2.	Optimization approaches:	
2.1.	Taxonomy of controller placement problem (CPP) optimization in SDN	[294]
2.2.	GAs with particle swarm optimization based mutation for distributed controller placement	[197]
2.3.	GA for controller placement in software-defined multi-hop wireless networks	[365]
2.4.	Novel controller placement algorithm based on network portioning concept and hybrid discrete optimization algorithm for multi-controller SDNs	[92]
2.5.	Parameter optimization model of heuristic algorithms (PSO) for controller placement in large-scale SDN	[192]
2.6.	Whale optimization for controller placement in SDN-WAN	[320]
2.7.	Bio-inspired multiverse optimization approach for controller placement in SDN	[249]
2.8.	Constrained evolutionary multiobjective optimization techniques for reliable controller placement in SDN	[270]
2.9.	Joint placement latency optimization of the control plane (mixed-integer linear programming)	[263]
2.10.	Multi-objective antlion algorithm for controller placements in SDNs	[154]
3.	Heuristics:	
3.1.	Heuristic approaches for the reliable controller placement problem	[299]
3.2.	Evaluating heuristic techniques as a solution of controller placement problem in SDN	[300]
3.3.	Using heuristics to the controller placement problem in software-defined multihop wireless networking	[363]
3.4.	Heuristic resource allocation algorithm for controller placement in multi-control 5G based on SDN/NFV architecture	[135]
3.5.	Parameter optimization model of heuristic algorithms (PSO) for controller placement in large-scale SDN	[192]
3.6.	Meta-heuristic approach for multi-controller placement in satellite SDN	[151]
3.7.	Nature-inspired metaheuristic algorithms for resilience controller placement in SDNs (experimental comparison of four nature-inspired metaheuristics)	[224]
3.8.	Efficient greedy heuristic approach for fault-tolerant distributed controller placement in scalable SDN architecture	[275]
3.9.	PSO and TLBO based reliable placement of controllers in SDN	[297]
3.10.	Metaheuristics (SA-MCSDN) optimizer for multi-controller placement in SDNs	[258]
4.	Evolutionary approaches:	
4.1.	Genetic algorithms for controller placement in SDNs	[12,87,141]
4.2.	Evolutionary multi-objective placement of SDN controllers in WSNs	[310]
4.3.	Multi-objective evolutionary optimization for cost-effective controller placement	[199]

Table 5. Basic solving approached for controller placement problems, part 2

No.	Method	Source(s)
5.	Multiobjective (multicriteria) methods:	
5.1.	Pareto-optimal resilient controller placement	[124]
5.2.	Multiobjective genetic algorithms	[12,87,141]
5.3.	Hybrid NSGA-II for solving multiobjective controller placement	[12]
5.4.	Multi-start hybrid non-dominated sorting GA-II (MHNSGA-II) (multicriteria combinatorial optimization model)	[142]
5.5.	Analytical Network Process approach	[22]
5.6.	Multiple criteria analysis of controller placement problem in SDNs (using AHP technique)	[143]
5.7.	Multi-objective optimization approach	[370]
5.8.	Adaptive multiobjective heuristic	[13]
5.9.	Evolutionary multi-objective placement of SDN controllers for optimizing cost and network performance in WSNs	[310]
5.10.	Pareto-optimal solutions for robust controller placement for link failure in SDNs	[130]
5.11.	Cost-effective controller placement scheme for software-defined vehicular networks (multi-objective evolutionary optimization, GA)	[199]
6.	AI-based method (machine learning, etc.):	
6.1.	Deep reinforcement learning for cost-effective controller placement in multihop wireless SDN	[364]
6.2.	Deep reinforcement learning based controller placement and optimal edge selection in SDN-based multi-access edge computing environments	[194]
6.3.	Reinforcement learning for dynamic controller deployment in LEO satellite networks	[79]
6.4.	AI techniques for traffic-aware dynamic controller placement (SDN-based aeronautical networks)	[212]
7.	Special methods:	
7.1.	Cooperative game theory based network partitioning approach	[160]
7.2.	Simulated annealing strategy for reliable controller placement in SDNs	[223]
7.3.	New GSO based method for SDN controller placement problem	[321]
7.4.	Clustering for controller placement (e.g., in SDN)	[25,54,196]
7.5.	Novel framework for capacitated SDN controller placement (balancing latency and reliability with PSO algorithm)	[301]
7.6.	Game theory and discrete hybrid metaheuristic algorithm for controller placement problem	[155]

4. Some basic formulations of controller placement problem

4.1. Basic parameters of controller placement problem

The basic list of problem parameters involves the following:

- (1) type of controllers: one type, multiple types;
- (2) type of network topology: tree-like topology, hierarchy, general network;
- (3) type of controllers layer: simple layer as controllers set, layer of connected controllers, layer as two tier controller set (local controllers, bottom-layer controllers); and
- (4) type of objective(s): one criterion (cost), multiple criteria.

4.2. Basic criteria/requirement in controller placement problems

In recent years controller placement problems have been examined under multiple criteria/requirements (e.g., [2,22,143,144,154,174,210,294]) (Fig. 10).

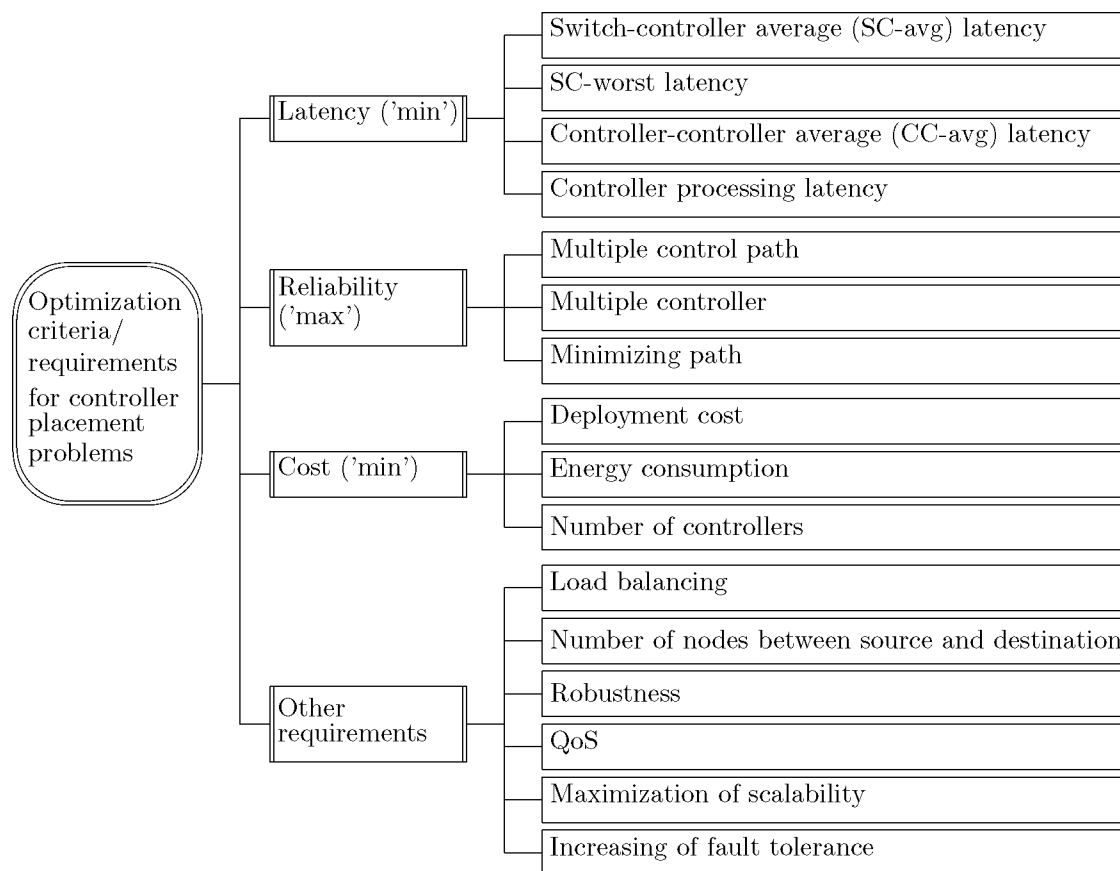

Fig. 10. Basic optimization criteria/requirements

4.3. Basic description and notations

Here the basic mathematical formulations of controller placement problem are described. The models are based on the following basic works [118,263]. Note that the considered optimization models are based on k -center problem (e.g., [185,186]) and the minimum k -means problem (e.g., [140]).

Usually the following notations are used [263]:

1. the initial graph (network) nodes/switches:
 - (1.1.) $G = (A, E)$, A is a set of all nodes/switches ($A = \{a_1, \dots, a_i, \dots, a_n\}$), E is the set of physical edges (links) between the nodes,
 - (1.2.) $B = \{b_1, \dots, b_\xi, \dots, b_k\}$ ($k < n$), is the set of installed controllers $B \subset A$.
2. $d_{i,j}$ is a distance between nodes $a_i, a_j \in A$ (here the distance is considered as a shortest path between the nodes).

3. $x_{i,\xi}$ is a binary variable: $x_{i,\xi} = 1$ if the node (switch) $a_i \in A$ is mapped (connected) to controller $b_\xi \in B$ and $x_{i,\xi} = 0$ otherwise.
4. $y_{i,\xi}$ is a binary variable: $y_{i,\xi} = 1$ if controller $b_\xi \in B$ is located at node $a_i \in A$ and $y_{i,\xi} = 0$ otherwise.
5. τ_{cs} is 'controller-switch' latency.
6. τ_{cc} is 'controller-controller' latency (or 'inter-controller' latency).
7. η_{cc} is the number of possible links between controllers, the number is $k(k-1)/2$.

4.4. Two basic formulations of controller placement problem

The basic controller placement problem was proposed in [118]. The joint latency optimization controller placement problem was described in [263]: In the problem the basic assumption is:

'The controller is collocated with a switch and each switch is managed by a single controller'.

Here (joint placement optimization) the goal is to find an optimal trade-off between (i.e., two objectives): (a) switch-controller latency τ_{cs} , and (b) inter-controller latency τ_{cc} . In [263] the objective functions are integrated with special weights/coefficients λ and $(1-\lambda)$ ($\lambda \in [0, 1]$):

$$\min (\lambda \tau_{cs} + (1 - \lambda) \tau_{cc}). \quad (1)$$

The following objectives are under consideration:

1. The latency between controllers and switches:

1.1. Average case latency scenario. The average latency between controllers and their assigned switches:

$$\tau_{cs}^a = (\sum_{a_i \in A, b_\xi \in B} d_{i,\xi} x_{i,\xi}) / (n - k) \quad (2)$$

The corresponding model is the minimum k -means problem.

1.2. Worst case latency scenario. The objective is to minimize the maximum latency between controllers and their assigned switches:

$$\tau_{cs}^w = \max_{b_\xi \in B} (d_{i,\xi} x_{i,\xi}) \quad a_i \in A, \quad b_\xi \in B \quad (3)$$

2. Inter-controller communication latency:

2.1. Average case latency scenario. The average inter-controller latency is minimized. The number of possible path among controllers is: $\eta_{cc} = k(k-1) / 2$. Here the average latency is:

$$\tau_{cc}^a = (\sum_{a_i \in A, b_\xi \in B} d_{i,\xi} x_{i,i} y_{\xi,\xi}) / \eta_{cc} \quad (4)$$

2.2. Worst case latency scenario. Here the longest distance between controllers is taken into account. The optimization problem is to minimize the maximum latency among controllers. The objective function is:

$$\tau_{cc}^w = \max_{b_\xi \in B} (d_{i,\xi} x_{i,\xi} y_{\xi,\xi}) \quad a_i \in A, \quad b_\xi \in B \quad (5)$$

In the models the following constraints are used as well:

$$\sum_{b_\xi \in B} = 1, \quad \forall a_i \in A \quad (6)$$

$$\sum_{a_i \in A} = 1, \quad \forall b_\xi \in B \quad (7)$$

$$y_{i,\xi} \leq x_{i,\xi}, \quad \forall a_i \in A, \quad \forall b_\xi \in B \quad (8)$$

$$x_{i,\xi}, y_{i,\xi} \in \{0, 1\} \quad i = \overline{1, n}, \quad \xi = \overline{1, k} \quad (9)$$

Here the above-mentioned constraints are used for the following:

- (a) constraint (6): every switch is assigned to exactly one controller;
- (b) constraint (7): each controller is located onto exactly one switch;
- (c) constraint (8): each switch a_i is mapped to controller b_ξ if controller b_ξ is placed at switch a_i ;
- (d) constraint (9): decision variables are binary (equal to 0 or 1).

Finally the following objective functions are examined in basic optimization models:

Problem 1. The basic controller placement problem (minimization of latency between switches and controllers; average case latency scenario) [118]:

$$\min \tau_{cs}^a. \quad (10)$$

Problem 2. The basic controller placement problem (minimization of latency between switches and controllers; worst case latency scenario) [118]:

$$\min \tau_{ts}^w. \quad (11)$$

Problem 3. Joint optimization of latency between switches and controllers and inter-controller latency - between controllers (for average case latency scenario) [263]:

$$\min (\lambda \tau_{cs}^a + (1 - \lambda) \tau_{cc}^a). \quad (12)$$

Problem 4. Joint optimization of latency between switches and controllers and inter-controller latency - between controllers (for worst case latency scenario) [263]:

$$\min (\lambda \tau_{cs}^w + (1 - \lambda) \tau_{cc}^w). \quad (13)$$

4.5. Two evident bi-criteria models

The evident bi-criteria optimization controller placement problems are as follows:

Problem 5. Two-criteria (vector) joint optimization of latency between switches and controllers and inter-controller latency - between controllers (for average case latency scenario):

$$(\min \tau_{cs}^a, \min \tau_{cc}^a). \quad (14)$$

Problem 6. Two-criteria (vector) joint optimization of latency between switches and controllers and inter-controller latency - between controllers (for worst case latency scenario):

$$(\min \tau_{cs}^w, \min \tau_{cc}^w). \quad (15)$$

4.6. On multi-criteria models

Evidently, the examination of multi-criteria (multi-objective) controller placement models is a vital contemporary research direction. Here the considered optimization models can be extended by the combination of the described criteria/requirements.

5. Some simple support solving strategies

There is an initial graph $A = (A, E)$ (A is a set of vertices, E is a set of edges). The problem consists in selection of a vertex subset $A' \subseteq A$ to locate the controller points. On the other hand, the problem is close to cluster head selection problem (Fig. 11). It is possible to consider the clustering (balanced clustering) of the initial network and assignment for obtained clusters the controller points (as an analogue of cluster heads). Clearly, an additional structure (e.g., hierarchical structure) over the controller points can be design as well.

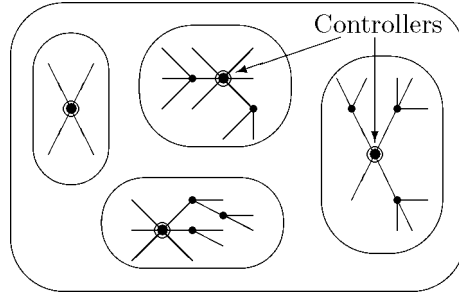

Fig. 11. Placement of controller points

The following simple support solving strategies can be listed:

Strategy 1. Basic placement (generation and selection) of controller points:

Step 1.1. Generation of controller points candidates $B \subseteq A$.

Step 1.2. Selection of the controller points $A' \subseteq B$ while taking into account attributes of the selected controller points and connections of the points to all other vertices $B = A \setminus A'$.

Strategy 2. Clustering-based strategy for placement of controller points (clustering and assignment/selection) (e.g., on the basis of k -means-based clustering approach [331]):

Step 2.1. Balanced clustering the initial graph to obtain clustering solution S (i.e., covering the graph G).

Step 2.2. Assignment/selection of the controller point for each cluster.

Strategy 3. Spanning tree (tree-like structure) based strategy for placement (location) of controller points:

Step 3.1. Designing the minimum spanning tree (or tree-like structure) T for the initial graph G .

Step 3.2. Balanced clustering the obtained T to obtain the clustering solution S^t .

Step 3.3. Assignment/selection of the controller point for each cluster.

Strategy 4. Combined degree-based with independent dominating set approach for controller placement problem (in SDN). Here a node degree-based algorithm named High Degree with Independent Dominating Set (HDIDS) for the controller placement problem is proposed [23]:

Step 4.1. Determining candidate controller instances by selecting those nodes with highest node degree.

Step 4.2. Partitioning the network into multiple domains, one controller per domain, exploiting the independent dominating set approach to ensure a distribution of controllers with lowest response times.

6. Some studies on clustering based controllers placement

Some studies of clustering based controllers placement are listed in Table 6.

Table 6. Some studies of clustering based controller placement

No.	Study	Support clustering scheme	Source(s)
1.	Controller placement in SDNs	Partitioning the network to maximize end-to-end latency between controllers and their associated switches	[331,332,335]
2.	Controller placement problem in large-scale SDNs	Density cluster based approach	[196]
3.	Framework for reliable controller placement in SDNs	Multicriteria clustering approach	[144]
4.	Multiobjective controller placement	Multicriteria network clustering (AHP)	[22]
5.	Controller placement in SDNs	Hierarchical k -means clustering	[173]
6.	Controller placement in SDNs	Spectral clustering	[209]
7.	Controller placement in SDNs	Fuzzy k -means clustering	[319]
8.	Distributed controller placement in SDN	Cluster leader election	[137]
9.	Controller placement based on cooperative games (for SDNs)	Network partitioning	[160]

7. Conclusion

This paper focuses on a systematic structured survey on controller placement problem in communication networks. Concurrently, an integrated glance to control/management issues in networks is presented as well. A general research effort is targeted to the usage of composite solving schemes based on combinatorial optimization models (i.e., clustering, k -center models, assignment/location, covering, domination/independent sets, knapsack problem, covering, multicriteria ranking -sorting). Two basic controller placement problem formulations are described. A special preliminary section contains a structured description for basic requirements and objectives which are used in controller placement problems. Some simplified support heuristic strategies are briefly described.

It may be reasonable to consider the following future research directions:

- (1) examination of other problem statements for controller placement problem (including problems under uncertainty);
- (2) an extended study of various solving schemes/frameworks for controller placement problem;
- (3) description and analysis of computing experiments for solving the controller placement problem in various modes (i.e., statical modes, dynamic/online mode);
- (4) consideration of placement problems in other networks (e.g., in electricity systems); and
- (5) using the controller placement problem in engineering and IT educational courses and projects.

The author states that there is no conflict of interest.

The research was supported by Russian Government, project No. FFNU-2025-0035 (Kharchevich Inst. for Information Transmission Problems of Russian Academy of Sciences).

REFERENCES

1. M.J. Abdel-Rahman, E.A. Mazied, A.B. MacKenzie, S.F. Midkiff, M.R.M. Rizk, M. El-Nainay, On stochastic controller placement problem in Software-Defined Wireless Networks. In: *IEEE Wireless Communications and Networking Conf. (WCNC)*, pp. 1–6, 2017. <https://doi.org/10.1109/WCNC.2017.7925942>
2. M.J. Abdel-Rahman, E.A. Mazied, K. Teague, A.B. MacKenzie, S.F. Midkiff, Robust controller placement and assignment in software-defined cellular networks. In: *2017 26th Int. Conf. on Comp. Commun. and Netw. (ICCCN)*, pp. 1–9, 2017. <https://doi.org/10.1109/ICCCN.2017.8038439>
3. A. Abderrahmane, H. Drid, A. Behaz1, A survey of controller placement problem in SDN-IoT network. *Int. J. of Networked and Distributed Computing*, 12, 170-184, 2024. <https://doi.org/10.1007/s44227-024-00035-y>
4. H. Abdulrab, F. A. Hussin, A. A. Aziz, A. Awang, I. Ismail, P.A.M. Devan Reliable fault tolerant-based multipath routing model for industrial wireless control systems *Applied Sciences*, 12(2), art. 544, 1–23, 2022. <https://doi.org/10.3390/app12020544>
5. A.S. Abohamama, E. Hamouda, A hybrid energy-aware virtual machine placement algorithm for cloud environments. *ESwA*, 150, art. 113306, 2020. <https://doi.org/10.1016/j.eswa.2020.113306>
6. A. Abuarqoub, A review of the control plane scalability in software defined networking. *Future Internet*, 12, art. 49, 1–14, 2020. <https://doi.org/10.3390/fi12030049>
7. B. Addis, D. Belabed, M. Bouet, S. Secci, Virtual network functions placement and routing optimization. In: *Proc. of the 2015 IEEE 4th Int. Conf. on Cloud Networking (CloudNet)*, pp. 171-177, 2015. <https://doi.org/10.1109/CloudNet.2015.7335301>
8. I.O. Adebayo, M.O. Adigun, P. Mudali, Centrality based algorithms for controller placements in software defined wide area networks. In: R.A. Saeed, A.D. Bakari, Y.H. Sheikh (eds), *Towards new e-Infrastructure and e-Services for Developing Countries. AFRICOMM 2022. Lecture Notes of the Inst. for Computer Sciences*, vol 499, Springer, pp 3-17, 2023. <https://doi.org/10.1007/978-3-031-34896-9>
9. Y. Afek, B. Awerbuch, S.A. Plotkin, M. Saks, Local management of a global resource in a communication network. *J. of the ACM*, 43(1), 1–19, 1996. <https://doi.org/10.1145/227595.22759>
10. A. Agarwal, T.N.B. Duong, Secure virtual machine placement in cloud data centers. *FGCS*, 100, 210–222, 2019. <https://doi.org/10.1016/j.future.2019.05.005>
11. S. Ahmad, A.H. Mir, Scalability, consistency, reliability and security in SDN controllers: a survey of diverse SDN controllers. *J. of Network and Systems Management*, 29. art. 9, 1–59, 2021. <https://doi.org/10.1007/s10922-20-09575-4>
12. V. Ahmadi, A. Jallili, S.M. Khorramizadeh, M. Keshtgari, A hybrid NSGA-II for solving multiobjective controller placement in SDN. In: *2015 2nd Int. Conf. on Knowledge-Based Engineering and Innovation (KBEI)*, pp. 663–669, 2015. <https://doi.org/10.1109/KBEI.2015.7436122>
13. V. Ahmadi, M. Khorramizadeh, An adaptive heuristic for multiobjective controller placement in software defined networks. *Comput. Elect. Eng.*, 66, 204–228, 2018. <https://doi.org/10.1016/j.compeleceng.2017.12.043>
14. A. Aissioui, A. Ksentini, A. Gueroui, T. Taleb, Toward elastic distributed SDN/NFV controller for 5G mobile cloud management systems. *IEEE Access*, 3, 2055–2064, 2015. <https://doi.org/10.1109/ACCESS.2015.2489930>
15. S.B. Akintoye, A. Bagula, Improving quality-of-service in Cloud/Fog computing through efficient resource allocation. *Sensors*, 19(6), art. 1267, 1–29, 2019. <https://doi.org/10.3390/s19061267>
16. I.F. Akyildiz, S.-C. Lin, P. Wang, Wireless software-defined networks (W-SDNs) and network function virtualization (NFV) for 5G cellular systems: an overview and qualitative evaluation *Comp. Netw.*, 93, Part 1, 66–79, 2015. <https://doi.org/10.1016/j.comnet.2015.10.013>
17. F. AL-Tam, N. Correia, Fractional switch migration in multi-controller software-defined networking. *Computer Network*, 157, 1–10, 2019. <https://doi.org/10.1016/j.comnet.2019.04.011>
18. A. Alashaikh, E. Alanazi, A. Al-Fugaha, A survey on the use of preferences for virtual machine placement in cloud data centers. *ACM Comput. Surv.*, 54(5), art. 96, 1–39, 2021. <https://doi.org/10.1145/3450517>
19. M. Albekairi, Controlled service scheduling scheme for user-centric software-defined network-based internet of things. *IEEE Access*, 13, 19199–19199, 2025. <https://doi.org/10.1109/ACCESS.2025.3533310>

20. A. Alhazmi, A. Moubayed, A. Shami, Distributed SDN controller placement using betweenness centrality & hierarchical clustering. In: Proc. of the 8th ACM Symp. on Design and Analysis of Intelligent Vehicular Networks and Applications DIVANet'18, pp. 15–20, 2018. <https://doi.org/10.1145/3272036.3272043>
21. F. Alharbi, Y.-C. Tian, M. Tang, W.-Z. Zhang, C. Peng, M. Fei, An ant colony system for energy-efficient dynamic Virtual Machine Placement in data centers. *ESWA*, 120, 228–238, 2019. <https://doi.org/10.1016/j.eswa.2018.11.029>
22. J. Ali, S. Lee, B.-h. Roh, Using the Analytical Network Process for controller placement in Software Defined Networks (poster). In: Proc. of the 17th Annual Int. Conf. on Mobile Systems, Applications, and Services – MobiSys'19, pp. 545–546, 2019. <https://doi.org/10.1145/3307334.3328617>
23. A. Alowa, T. Fevens, Combined degree-based with independent dominating set approach for controller placement problem in software defined networks. In: 22nd Conf. on Innovation in Clouds, Internet and Networks and Workshops (ICIN), pp. 269–276, 2019. <https://doi.org/10.1109/ICIN.2019.8685897>
24. A. Alowa, T. Fevens, Y. Khamayseh, Survival backup strategy for controller placement problem in Software Defined Networking. *Computer Communications*, 185, 104–117, 2022. <https://doi.org/10.1016/j.comcom.2021.12.020>
25. A. Amin, M. Jahanshahi, M.R. Meybodi, Improved learning-automata-based clustering method for controller placement problem in SDN. *Applied Sciences*, 13(18), art. 10073, 1–16, 2023. <https://doi.org/10.3390/app131810073>
26. O.M. Amine, A. Khireddine, Base station placement optimisation using genetic algorithms approach. *Int. J. Comput. Aided Eng. Technol.*, 11(6), 635–652, 2019. <https://doi.org/10.1504/IJCAET.2019.102495>
27. A.Q. Ansari, P. Saxena, K.D. Gupta, Channel allocation with sub-optimal power control in WiMAX networks using fuzzy inference system. *Procedia CS*, 57, 152–159, 2015. <https://doi.org/10.1016/j.procs.2015.07.405>
28. D. Antunes, J. Hespanha, C. Silvestre, Stability of networked control systems with asynchronous renewal links: an impulsive systems approach. *Automatica*, 49(2), 402–413, 2013. <https://doi.org/10.1016/j.automatica.2012.11.033>
29. B. Aoun, R. Boutaba, Y. Iraqi, G. Kenward, Gateway placement optimization in wireless mesh networks with QoS constraints. *IEEE J. on Sel. Areas in Commun.*, 24(11), 2127–2136, 2006. <https://doi.org/JSAC.2006.881606>
30. A. Aspeel, K. Rutledge, R.M. Jungers, B. Macq, N. Ozay, Optimal control for linear networked control systems with information transmission constraints. *Electr. prepr.*, 8 p., Sep. 22, 2021. <https://doi.org/48550/arXiv.2109.10666>
31. W. Attaoui, E. Sabir, H. Elniaze, M. Guizani, VNF and CHF placement in 5G: recent advances and future trends. *IEEE Trans. on Networks and Service Management*, 20(4), 4698–4733, 2023. <https://doi.org/10.1109/TNSM.2023.3264005>
32. S. Auroux, H. Karl, Flow processing-aware controller placement in wireless DenseNets. In: Proc. of the IEEE PIMRC Conf., pp. 1294–1299, 2014. <https://doi.org/10.1109/PIMRC.2014.7136368>
33. A. Aybar, A. Iftar, Supervisory controller design to enforce some basic properties in timed-transition Petri nets using stretching. *Nonlinear Analysis: Hybrid Systems*, 6, 712–729, 2012. <https://doi.org/10.1016/j.nahs.2011.07.002>
34. V. Azhmyakov, R. Galvan-Guerra, A. Poznyak, On the hybrid LQ-based control design for linear networked systems. *J. of the Franklin Institute*, 347, 1214–1226, 2010. <https://doi.org/10.1016/j.franklin.2010.05.012>
35. N. Babu, C.B. Papadas, P. Popovski, Energy-efficient 3-D deployment of aerial access point in a UAV communication system. *IEEE Commun. Lett.*, 24(12), 2883–2887, 2020. <https://doi.org/10.1109/LCOMM.2020.3017559>
36. W.E.G. Bachur, E.N. Goncalves, J.A. Ramirez, L.S. Batista, A multiobjective robust controller synthesis approach aided by multicriteria decision analysis. *Appl. Soft Comput.*, 60, 274–386, 2017. <https://doi.org/10.1016/j.asoc.2017.06.027>
37. J.C.M. Baeten, J.M. van de Mortel-Fronczak, J.E. Rooda, Integration of supervisory control synthesis in model-based systems engineering. In: G.M. Dimirovski (ed), *Complex Systems*. Springer, pp. 39–58, 2016. <https://doi.org/10.1007/978-3-319-28860-4>

38. D. Baker, A. Ephremides, J. Flynn, The design and simulation of a mobile radio network with distributed control. *IEEE J. on Sel. Areas in Commun.*, 2(1), 226-237, 1984. <https://doi.org/10.1109/JSAC.1984.1146043>
39. I. Ban, S.-J. Kim, Intelligent dynamic power control with cell range expansion for small-cells in 5G HetNets. *Appl. Sci.*, 14, art. 3789, 1–15, 2024. <https://doi.org/10.3390/app14093789>
40. S. Banerjee, S. Khuller, A clustering scheme for hierarchical control in multi-hop wireless networks. In: *Proc. of IEEE INFOCOM 2001*, vol. 2, pp. 1028–1037, 2001. <https://doi.org/10.1109/INFCOM.2001.916296>
41. F. Bannour, S. Souihi, A. Mellouk, Distributed SDN control: survey, taxonomy, and challenges. *IEEE Commun. Surv. & Tut.*, 20(1), 333–354, 2018. <http://doi.org/10.1109/COMST.2017.2782482>
42. Y. Bar David, T. Geller, I. Bistriz, I. Ben-Gal, N. Bambos, E. Khmelnitsky, Wireless body area network control policies for energy-efficient health monitoring. *Sensors*, 21(12), art. 4245, 1–21, 2021. <https://doi.org/10.3390/s21124245>
43. J. Bar-Ilan, G. Kortsarz, D. Peleg, How to allocate network centers. *J. of Algorithms*, 15(3), 385–415, 1993. <https://doi.org/10.1006/jagm.1993.1047>
44. M.F. Bari, A.R. Roy, S.R. Chowdhury, Q. Zhang, M.F. Zhani, R. Ahmed, R. Boutaba, Dynamic controller provisioning in software defined networks. In: *2013 9th Int. Conf. on Netw. and Serv. Manag. (CNSM)*, pp. 18-25, 2013. <https://doi.org/10.1109/CNSM.2013.6727805>.
45. A. Barolli, K. Bylykbashi, E. Qafzezi, S. Sakamoto, L. Barolli, A comparison study of Weibull, normal and Boulevard distributions for wireless mesh networks considering different router replacement methods by a hybrid intelligent simulation system. *J. of Ambient Intell. and Humanized Comput.*, 14, 10181–10194, 2023. <https://doi.org/10.1007/s12652-021-03680-1>
46. D. Benyamina, A. Hafid, M. Gendreau, Optimal placement of gateways in multi-hop wireless mesh networks: a clustering-based approach. In: *IEEE 34th Conf. on Local Computer Netw.*, pp. 625–632, 2009. <https://doi.org/10.1109/LCN.2009.5355141>
47. S. Bera, S. Misra, N. Saha, Traffic-aware dynamic controller assignment in SDN. *IEEE Trans. on Commun.*, 68(7), 4375–4382, 2020. <https://doi.org/10.1109/TCOMM.2020.2983168>
48. T.Y. Berger-Wolf, W.E. Hart, J. Saia, Discrete sensor placement problems in distributed networks. *Math. and Comp. Modelling*, 42, 1385–1396, 2005. <https://doi.org/10.1016/j.mcm.2005.03.005>
49. I.Z. Bholebawa, U.D. Dalal, Performance analysis of SDN/OpenFlow controllers: POX versus floodlight. *Wir. Pers. Commun.*, 98(2), 1679–1699, 2018. <https://doi.org/10.1007/s11277-017-4939-z>
50. T. Bilen, K. Ayvaz, B. Canberk, QoS-based distributed flow management in software defined ultradense networks. *Ad Hoc Networks*, 78, 24-31, 2018. <https://doi.org/10.1016/j.adhoc.2018.05.002>
51. I. Bistriz, N. Bambos, Power is knowledge: distributed and throughput optimal power control in wireless networks. *IEEE/ACM Trans. on Networking*, 32(6), 4722–4734, 2024. <https://doi.org/doi.org/10.1109/TNET.2024.3444602>
52. R. Bixby, E. Rothberg, Progress in computational mixed integer programming: A look back from the other side of the tipping point. *Ann. Oper. Res.*, 149, 37–41, 2007. <https://doi.org/10.1007/s10479-006-0091-y>
53. O. Bliat, M.B. Mamoun, R. Benaini, An overview on SDN architectures with multiple controllers. *J. of Computer Netw. and Commun.*, Volume 2016, Art. ID 9396525, 1–8, 2016. <https://doi.org/10.1155/2016/9396525>
54. E.H. Bouzidi, A. Outtagarts, R. Langar, R. Boutaba, Dynamic clustering of software defined network switches and controller placement using deep reinforcement learning. *Computer Networks*, 207, art. 108852, 2022. <https://doi.org/10.1016/j.comnet.2022.108852>
55. R. Burkard, M. Dell'Amico, S. Martello, *Assignment Problems*. Revised reprint. SIAM, Providence, 2012. ISBN: 978-1-611972-22-1
56. K. Cai, W. Wonham, Supervisor localization: a top-down approach to distributed control of discrete-event systems. *IEEE Trans. Autom. Control*, 55(3), 605–618, 2010. <https://doi.org/10.1109/TAC.2009.2039237>
57. H. Calik, M. Labbe, H. Yaman, p -center problems. In: G. Laporte et al. (eds.), *Location Science*, Springer, pp. 79–92, 2015. <https://doi.org/10.1007/978-3-319-13111-5>
58. E. Cela, *The Quadratic Assignment Problem: Theory and Algorithms*. Springer, 1998. <https://doi.org/10.1007/978-1-4757-2787-6>

59. L.E. Celis, F. Pavetic, B. Spinelli, P. Thiran, Budgeted sensor placement for source localization on trees. *Electr. Notes in Discr. Math.*, 50, 65–70, 2015. <https://doi.org/10.1016/j.endm.2015.07.012>
60. A. Cetinkaya, H. Ishii, T. Hayakawa, Random and malicious packet transmission failures on multi-hop channels in networked control systems. *IFAC-PapersOnLine*, 49–22, 49–54, 2016. <https://doi.org/10.1016/j.ifacol.2016.10.371>
61. R. Chai, Q. Yuan, L. Zhu, Q. Chen, Control plane delay minimization-based capacitated controller placement algorithm for SDN. *EURASIP J. on Wireless Comm. and Network.*, art. 282, 1–17, 2019. <https://doi.org/10.1186/s13638-019-1607-x>
62. R. Chai, Q. Yuan, C. Du, Q. Chen, Network cost optimization-based capacitated controller deployment for SDN. *Computer Networks*, 197, art. 108326, 1–11, 2021. <https://doi.org/10.1016/j.comnet.2021.108326>
63. C.-Y. Chang, H.-R. Chang, Energy-aware node placement, topology control and MAC scheduling for wireless sensor networks. *Comput. Netw.*, 52(11), 2189–2204, 2008. <https://doi.org/10.1016/j.comnet.2008.02.028>
64. C. Chaudet, E. Fleury, H. Rivano, Optimal positioning of active and passive monitoring devices. In: *Proc. of the 2005 ACM Conf. on Emerging Network Experiment and Technology CoNEXT'05*, pp. 71–82, 2005. <https://doi.org/10.1145/1095921.1095932>
65. F.C. Chen, R.L. Li, Sink node placement strategies for wireless sensor networks. *Wireless Personalized Communications*, 68(2), 303–319, 2013. <https://doi.org/10.1007/s11277-011-0453-x>
66. T.Y. Cheng, M. Wang, X. Jia, QoS-Guaranteed controller placement in SDN. In: *Proc. of the 2015 IEEE Global Communications Conf. (GLOBECOM)*, pp. 1–6, 2015. <https://doi.org/10.1109/GLOCOM.2015.7416960>
67. R. Chiong, Th. Weise, Z. Michalewicz (eds), *Variants of Evolutionary Algorithms for Real-World Applications*. Springer, 2012. <https://doi.org/10.1007/978-3-642-23424-8>
68. T.M. Chiwewe, G.P. Hancke, A distributed topology control techniques for low interference and energy efficiency in wireless sensor networks. *IEEE Trans. on Industrial Informatics*, 8(1), 11–19, 2012. <https://doi.org/10.1109/TII.2011.2166778>
69. J. Cortes, S. Martinez, T. Karatas, F. Bullo, Coverage control for mobile sensing networks. *IEEE Trans. on Robotics and Automation*, 20(2), 243–255, 2004. <https://doi.org/10.1109/TRA.2004.824698>
70. M. Damian, S. Pandit, S. Pemmaraju, Local approximation schemes for topology control. *Electr. prepr.*, 11 p., Mar. 14, 2008. <http://arxiv.org/abs/0803.2174> [cs.DS]
71. T. Darwish, T.A. Alhaj, F.A. Elhaj, Controller placement in software defined emerging networks: a review and future directions. *Telecommunication Systems*, 88(1), art. 18, 1–31, 2025. <https://doi.org/10.1007/s11235-024-01252-0>
72. T. Das, V. Sridharan, M. Gurusamy, A survey on controller placement in SDNs. *IEEE Commun. Surv.&Tut.*, 22(1), 472–503, 2020. <https://doi.org/10.1009/2019.2935453>
73. D. Das, J. Bapat, D. Das, Unsupervised learning based capacity augmentation in SDN assisted wireless networks. *SN Computer Science*, 1(4), art. 230, 1–13, 2020. <https://doi.org/10.1007/s42979-020-00233-9>
74. M.S. Daskin, *Network and Discrete Location: Models, Algorithms, and Applications*. New York, Wiley, 1995. <https://doi.org/10.1002/9781118032343>
75. J. Davila, A. Pisano, E. Usal, Finite-time observation of the continuous and discrete state for a class of nonlinear switched dynamics. *IFAC Proceedings Volumes*, 42(17), 358–363, 2009. <https://doi.org/10.3182/20090916-3-ES-3003.00062>
76. G. Deconinck, K. Thoelen, Lessons from 10 years of demand response research. *Smart energy for customers? IEEE Systems, Man, & Cybernetics Magazine*, 5(3), 21–30, 2019. <https://doi.org/10.1109/MSMC.2019.2920160>
77. S. Demirci, S. Sagiroglu, Optimal placement of virtual network functions in software defined networks: a survey. *J. of Network and Computer Applications*, 147, art. 102424, Dec. 2019. <https://doi.org/10.1016/j.jnca.2019.102424>
78. S. Demirci, M. Demirci, S. Sagiroglu, Virtual security functions and their placement in software defined networks: a survey. *Gazi University J. of Science*, 32(3), 833–851, 2019.
79. Y. Deng, F. Yao, J. Zhu, Reinforcement learning and genetic algorithm-based dynamic controller deployment for Low Earth Orbit satellite networks. *Advances in Space Research*, 77(2), 2203–2221,

2026. <https://doi.org/10.1016/j.asr.2025.10.021>
80. A. Dixit, F. Hao, S. Mukherjee, T.V. Lakshman, R. Kompella, Towards an elastic distributed SDN controller. *ACM SIGCOMM Computer Communication Review*, 43(4), 7–12, 2013. <https://doi.org/10.1145/2534169.2491193>
 81. M.C.F. Donkers, W.P.M.H. Heemels, N. van de Wouw, L. Hetel, Stability analysis of networked control systems using a switched linear systems approach. *IEEE Trans. on Automatic Control*, 56(9), 2101–2115, 2011. <https://doi.org/10.1109/TAC.2011.2107631>
 82. S. Dou, L. Qi, C. Yao, Z. Guo, Exploring the impact of critical programmability on controller placement for software-defined wide area networks. *IEEE/ACM Trans. on Networking*, 31(6), 2575–2588, 2023. <https://doi.org/10.1109/TNET.2023.3252639>
 83. D.-Z. Du, P.-J. Wan, *Connected Dominating Set: Theory and Applications*. Springer, 2013. <https://doi.org/10.1007/978-1-4614-5242-3>
 84. J. Du, A thermodynamic approach to measurement selection for process networks. *IFAC Proceedings Volumes*, vol. 1, 90–95, 2013. <https://doi.org/10.3182/20130714-3-FR-4040.00013>
 85. A. Dvir, Y. Haddad, A. Zilberman, The controller placement problem for wireless SDN. *Wireless Networks*, 25(8), 4963–4978, 2019. <https://doi.org/10.1007/s11276-019-02077-5>
 86. A.E. Eiben, J.E. Smith, *Introduction to Evolutionary Computing*. Springer, 2015. <https://doi.org/10.1007/978-3-662-44874-8>
 87. Y. Fan, L. Wang, X. Yuan, Controller placements for latency minimization of both primary and backup paths in SDNs. *Comp. Commun.*, 163, 35–50, 2020. <https://doi.org/10.1016/j.comcom.2020.09.001>
 88. R.Z. Farahani, M. Hekmatfar, B. Fahimnia, N. Kazemzadeh, An efficient placement of sinks and SDN controller nodes for optimizing the design cost of industrial IoT systems. *J. of Software Practice and Experiments*, 48(10), 1893–1919, 2018. <https://doi.org/10.1002/spe.2593>
 89. S. Farzai, M.H. Shirvani, M. Rabbani, Multi-objective communication-aware optimization for virtual machine placement in cloud datacenters. *Sustainable Computing: Informatics and Systems*, 28, art. 100374, 2020. <https://doi.org/10.1016/j.suscom.2020.100374>
 90. J.L.K.E. Fendji, C. Thron, A simulated annealing based centre of mass (SAC) approach for mesh router placement in rural areas. *Int. J. of Oper. Res. and Inform. Systems*, 11(1), 37–65, 2020. <https://doi.org/10.4018/IJORIS.2020010102>
 91. M.C.S. Filho, C.C. Monteiro, P.R.M. Inacio, M.M. Freire, Approaches for optimizing virtual machine placement and migration in cloud environments: a survey. *J. Parallel Distrib. Comput.*, 111, 222–250, 2018. <https://doi.org/10.1016/j.jpdc.2017.08.010>
 92. N. Firouz, M. Masdari, A.B. Sangar, K. Majidzadeh, A novel controller placement algorithm based on network portioning concept and a hybrid discrete optimization algorithm for multi-controller software-defined networks. *Clust. Comput.*, 24, 2511–2544, 2021. <https://doi.org/10.1007/s10586-021-03264-w>
 93. R. Firouzi, A. Rahmani, A distributed SDN controllers for distributed IoT. *IEEE Access*, 10, 42873–42882, 2022. <https://doi.org/10.1109/ACCESS.2022.3168299>
 94. Y. Fu, Y. Chen, C.W. Sung, Distributed power control for the downlink of multi-cell NOMA systems. *IEEE Trans. on Wir. Commun.*, 19(6), 6207–6220, 2017. <https://doi.org/10.1109/TWC.2017.2720743>
 95. T. Fukunaga, S. Hirahara, H. Yoshikawa, Virtual machine placement for minimizing connection cost in data center networks. *Discr. Optim.*, 26, 183–198, 2017. <https://doi.org/10.1016/j.disopt.2017.05.004>
 96. A. Gabillon, R. Gallier, E. Bruno, Access control for IoT networks. *SN Computer Science*, 1, art. 24, 2020. <https://doi.org/10.1007/s42979-019-0022-z>
 97. M.R. Garey, D.S. Johnson, *Computers and Intractability. The Guide to the Theory of NP-Completeness*. W.H. Freeman, San-Francisco, 1979. <https://doi.org/10.5555/574848>
 98. B. Gavish, Topological design of telecommunication networks - the overall design problem. *EJOR*, 58(2), 149–172, 1992. [https://doi.org/10.1016/0377-2217\(92\)90204-M](https://doi.org/10.1016/0377-2217(92)90204-M)
 99. H. Giannopoulos, A.M. Wyglinski, J. Chapman, Securing vehicular controller area networks: an approach to active bus-level countermeasures. *IEEE Trans. on Vehicular Technology*, 12(4), 60–68, 2017. <https://doi.org/10.1109/MVT.2017.2647814>
 100. S.S.A. Gilani, A. Qayyum, R.N. Bin Rais, M. Bano, SDNMesh: an SDN based routing architecture for wireless mesh networks. *IEEE Access*, 8, 136769–136781, 2020. <https://doi.org/10.1109/ACCESS.2020.3011651>

- 101.F. Giust, L. Cominardi, C.J. Bernardos, Distributed mobility management for future 5G networks. *IEEE Commun. Mag.*, 53(1), 142–149, 2015. <https://doi.org/10.1109/MCOM.2015.7010527>
- 102.G.C. Goodwin, D.E. Quevedo, E.I. Silva, Architectures and coder design for networked control systems. *Automatica*, 44(1), 248–257, 2008. <https://doi.org/10.1016/j.automatica.2007.05.015>
- 103.G.R. Gopal, B.D. Rao, G.P. Villardi, Access point placement for hybrid UAV-terrestrial small-cell networks. *IEEE Open J. of the Communication Society*, 2, 1826–1841, 2021. <https://doi.org/10.1109/OJCOMS.2021.3100060>
- 104.G.R. Gopal, B.D. Rao, Vector optimization methods for access points placement in cell-free massive MIMO systems. *IEEE Trans. on Wireless Commun.*, 23(6), 5425–5440, 2024. <https://doi.org/10.1109/TWC.2023.3326453>
- 105.M.A. Gorelov, F.I. Ereshko, A wareness and control decentralization. *Aut. and Rem. Control*, 80(6), 1109–1122, 2019. <https://doi.org/10.1134/S0005117919060092>
- 106.F. Goudarzi, H. Asgari, H.S. Al-Raweshidi, Fair and stable joint beacon frequency and power control for connected vehicles. *Wireless Networks*, 25(8), 4979–4990, 2019. <https://doi.org/10.1007/s11276-019-02076-6>
- 107.B. Groza, P. Murvay, Efficient intrusion detection with bloom filtering in controller area networks. *IEEE Trans. on Information Forensics and Security*, 14(4), 1037–1051, 2019. <https://doi.org/10.1109/TIFS.2018.2869351>
- 108.M. Guo, P. Bhattacharya, Controller placement for improving resilience of software-defined networks. In: 2013 Fourth Int. Conf. on Networking and Distributed Computing, pp. 23–27, 2013. <https://doi.org/10.1109/ICNDC.2013.15>
- 109.W. Guo, V. Mahendran, S. Radhakrishnan, Join and spilt TCP for SDN networks: Architecture, implementation and evaluation. *Comp. Netw.*, 137, 160–172, 2018. <https://doi.org/10.1016/j.comnet.2018.03.022>
- 110.S.L. Hakimi, Optimum distribution of switching centers and the absolute centers and medians of a graph. *Operations Research*, 12(3), 450–459, 1964. <https://doi.org/10.1287/opre.12.3.450>
- 111.S.L. Hakimi, Optimum distribution of switching centers in a communication network and some related graph theoretic problems. *Operations Research*, 13(3), 462–475, 1965. <https://doi.org/10.1287/opre.13.3.462>
- 112.I. Hamzaoui, B. Duthil, V. Courboulay, H. Medromi, A survey on the current challenges of energy-efficient cloud resources management. *SN Computer Science*, vol. 1, art. 73, 1–28, 2020. <https://doi.org/10.1007/s42979-020-0078-9>
- 113.T. Han, Z. Lin, M. Fu, Formation merging control in 3D under directed and switching technology. *IFAC Proceedings Volumes*, 47(3), 10036–10041, 2014. <https://doi.org/10.3182/20140824-6-ZA-1003.02182>
- 114.L. Han, Z. Le, W. Liu, K. Dai, W. Qu, Minimum control latency of SDN controller placement. In: Proc. IEEE Trustcom/BigDataSE/ISPA, pp. 2175–2180, 2016. <https://doi.org/10.1109/TrustCom.2016.0334>
- 115.X. Han, Z. Ji, Q. Qi, Optimal control for networked control systems with Markovian packet losses. *Complexity*, art. ID 4804320, 1–11, 2020. <https://doi.org/10.1155/2020/4804320>
- 116.Q. He, R.S. Blum, H. Godrich, A.M. Haimovich, Target velocity estimation and antenna placement for MIMO radar with widely separated antennas. *IEEE J. of Selected Topics in Signal Processing*, 4(1), 79–100, 2010. <https://doi.org/10.1109/JSTSP.2009.2038974>
- 117.W.M.H. Heemels, A.R. Teel, N. Van de Wouw, D. Nesic, Networked control systems with communication constraints: tradeoffs between transmission intervals, delay and performance. *IEEE Trans. on Automatic Control*, 55(8), 1781–1796, 2010. <https://doi.org/10.1109/TAC.2010.2042352>
- 118.B. Heller, R. Sherwood, N. McKeown, The controller placement problem. In: Proc. 1st Workshop Hot Topics Softw. Defined Netw. HotSDN'12, pp. 7–12, 2012. <https://doi.org/10.1145/2342441.2342444>
- 119.M.A. Henning, N.J. Rad, Locating-total domination in graphs. *Discr. Appl. Math.*, 160, 1986–1993, 2012. <https://doi.org/10.1016/j.dam.2012.04.004>
- 120.M.P. Hernandez, D. MvFarlane, M. Herrera, A.K. Jain, A.K. Parlikad, Comparing agent-based control architectures for next generation telecommunication network infrastructures. *IFAC PapersOnLine*, 53(2), 11062–11067, 2020. <https://doi.org/10.1016/j.ifacol.2020.12.238>
- 121.J.P. Hespanha, P. Naghshtabrizi, Y. Xu, A survey of recent results in networked control systems.

- Proc. of the IEEE, 95(1), 138–162, 2007. <https://doi.org/10.1109/JPROC.2006.887288>
- 122.D.H. Ho, T.A. Gulliver, Prioritized cell association and power control in uplink heterogeneous networks. *IEEE Access*, 8, 1209–1223, 2020. <https://doi.org/10.1109/ACCESS.2019.2961968>
- 123.D.S. Hochbaum, A. Pathria, Generalized p-center problems: complexity results and approximation algorithms. *EJOR*, 100(3), 594–607, 1997. [https://doi.org/10.1016/S0377-2217\(96\)00076-8](https://doi.org/10.1016/S0377-2217(96)00076-8)
- 124.D. Hock, M. Hartmann, S. Gebert, M. Jarschel, T. Zimmer, P. Tran-Gia, Pareto-optimal resilient controller placement in SDN-based core networks. In: 2013 25th Int. Teletraffic Congress (ITC), pp. 1–9, 2013. <https://doi.org/10.1109/ITC.2013.6662939>
- 125.E.H. Houssein, M.R. Saad, K. Hussain, W. Zhu, H. Shaban, M. Hassaballah, Optimal sink node placement in large scale wireless sensor networks based on Harris’ hawk optimization algorithm. *IEEE Access*, 8, 19381–19397, 2020. <https://doi.org/10.1109/ACCESS.2020.2968981>
- 126.Y.N. Hu, W.D. Wang, X.Y. Gong, X.R. Que, S.D. Cheng, On the placement of controllers in software-defined networks. *J. of China Universities of Post and Telecommunications*, 19, Suppl. 2, 92–171, 2012. [https://doi.org/10.1016/S1005-8885\(11\)60438-X](https://doi.org/10.1016/S1005-8885(11)60438-X)
- 127.Y. Hu, T. Luo, W. Wang, C. Deng, On the load balanced controller placement problem in software defined networks. In: 2016 2nd IEEE Int. Conf. on Computer and Communications (ICCC), pp. 2430–2434, 2016. doi: 10.1109/CompComm.2016.7925135
- 128.Y. Hu, T. Luo, N.C. Beaulieu, The energy-aware controller placement problem in software defined networks. *IEEE Communications Lett.*, 21(4), 741–744, 2017. <https://doi.org/10.1109/LCOMM.2016.2645558>
- 129.T. Hu, Z. Guo, T. Baker, J. Lan, Multi-controller based software-defined networking: a survey. *IEEE Access*, 6, 15980–15996, 2018. <https://doi.org/10.1109/ACCESS.2018.2814738>
- 130.T. Hu, Q. Ren, P. Yi, Z. Li, J. Lan, Y. Hu, Q. Li, An efficient approach to robust controller placement for link failure in Software-Defined Networks. *FGCS*, 124, 187–205, 2021. <https://doi.org/10.1016/j.future.2021.05.022>
- 131.V. Huang, G. Chen, Q. Fu, E. Wen, Optimizing controller placement for software defined networks. *Electr. prepr.*, 9 p., Feb. 14, 2019. <https://doi.org/10.48550/arXiv.1902.09451>
- 132.M. Huang, L. Huang, S. Zhong, P. Zhang, UAV-mounted mobile base station placement via sparse recovery. *IEEE Access*, 8, 71775–71781, 2020. <https://doi.org/10.1109/ACCESS.2020.2987851>
- 133.S. Iacovella, F. Ruelens, P. Vingerhoets, B. Claessens, G. Deconinck, Cluster control of heterogeneous thermostatically controlled loads using tracer limits. *IEEE Trans. Smart Grids*, 8(2), 528–536, 2017. <https://doi.org/10.1109/TSG.2015.2483506>
- 134.M. Ibrahim, M. Imran, F. Jamil, Y.-J. Lee, D.-H. Kim, EAMA: efficient adaptive migration algorithm for cloud data centers (CDCs). *Symmetry*, 13(4), art. 690, 1–19, 2021. <https://doi.org/10.3390/sym13040690>
- 135.A.A.Z. Ibrahim, F. Hashim, N.K. Noordin, A. Sali, K. Navaie, S.M.E. Fadul, Heuristic resource allocation algorithm for controller placement in multi-control 5G based on SDN/NFV architecture. *IEEE Access*, 9, 2602–2617, 2021. <https://doi.org/10.1109/ACCESS.2020.3047210>
- 136.O.C. Imer, S. Yksel, T. Basar, Optimal control of LTI systems over unreliable communication links. *Automatica*, 42(9), 1429–1439, 2006. <https://doi.org/10.1016/j.automatica.2006.03.011>
- 137.G. Ishigaki, R. Gour, A. Yousefpour, N. Shinomiya, J.P. Jue, Cluster leader election problem for distributed controller placement in SDN. In: Proc. IEEE Global Commun. Conf. (GLOBECOM), pp. 1–6, 2017. <https://doi.org/10.1109/GLOCOM.2017.8254748>
- 138.B. Isong, R.R.S. Molose, A.M. Abu-Mahfouz, N. Dladlu, Comprehensive review of SDN controller placement strategies. *IEEE Access*, 8, 170070–170092, 2020. <https://doi.org/10.1109/ACCESS.2020.3023974>
- 139.J. Jacob, S. Shinde, D.G. Narayan, An efficient controller placement algorithm using clustering in software defined networks. *J. of Telecommunications and Information Technology*, 4, 9–17, 2023. <https://doi.org/10.26636/jtit.2023.4.1371>
- 140.A.K. Jain, M.N. Murty, P.J. Flynn, Data clustering: a review. *ACM Comput. Surv.*, 31(3), 264–323, 1999. <https://doi.org/10.1145/331499.331504>
- 141.A. Jalili, V. Ahmadi, M. Keshtgari, M. Kazemi, Controller placement in software-defined WAN using multi objective genetic algorithm. In: 2015 2nd Int. Conf. on Knowledge-Based Engineering and Innovation (KBEI), pp. 656–662, 2015. <https://doi.org/10.1109/KBEI.2015.7436121>

- 142.A. Jalili, M. Keshtgari, R. Akbari, Optimal controller placement in large scale software defined networks based on modified NSGA-II. *Applied Intell.*, 48(9), 2809–2823, 2018. <https://doi.org/10.1007/s10489-017-1119-5>
- 143.A. Jalili, M. Keshtgari, R. Akbari, R. Javidan, Multi criteria analysis of Controller Placement Problem in Software Defined Networks. *Computer Communications*, 133, 115–128, 2019. <https://doi.org/10.1007/s10489-017-1119-5>
- 144.A. Jalili, M. Keshtgari, R. Akbari, R. Javidan, A new framework for reliable control placement in software defined networks based on multi-criteria clustering approach. *Soft Computing*, 24, 2897–2916, 2020. <https://doi.org/10.1007/s00500-019-04070-8>
- 145.A. Jalili, M. Keshtgari, A new reliable controller placement model for software-defined WANs. *J. of AI and Data Mining*, 8(2), 269–277, 2020. <http://doi.org/10.22044/JADM.2019.6319.1745>
- 146.S. Jamali, S. Malektaji, M. Analoui, An imperialist competitive algorithm for virtual machine placement in cloud computing. *J. Exper. Theor. Artif. Intell.*, 29(3), 575–596, 2017. <https://doi.org/10.1080/0952813X.2016.1212101>
- 147.S. Jardosh, P. Ranjan, A survey: topology control for wireless sensor networks. In: *Int. Conf. on Signal Processing Communications and Networking 2008 ICSCN'08*, pp. 422–427, 2008. <https://doi.org/10.1109/ICSCN.2008.4447231>
- 148.A. Jauhri, J.D. Lohn, D.S. Linden, A comparison of antenna placement algorithms. In: *Proc. of the 2014 Annual Conf. on Genetic and Evolutionary Computation GECCO/14*, pp. 1223–1230, 2014. <https://doi.org/10.1145/2598394.2605446>
- 149.S. Ji, D. Guo, R. Gao, T. Mai, Dynamic assignment of software-defined controllers in vehicle networks: an evolutionary game approach. In: *2023 Int. Wireless Communications and Mobile Computing (IWCMC)*, pp. 1383–1388, 2023. <https://doi.org/10.1109/IWCMC58020.2023.10182606>
- 150.J. Jia, J. Chen, G. Chang, Z. Tan, Energy efficient coverage control in wireless sensor networks based on multi-objective genetic algorithm. *Computers and Mathematics with Applications*, 57(11–12), 1756–1766, 2009. <https://doi.org/10.1016/j.camwa.2008.10.036>
- 151.W.w. Jiang, H. Han, Y. Zhang, J. Mu, Multi-controller placement in software defined satellite networks: a meta-heuristic approach. In: *2024 IEEE Vehicular Technology Conf. (VTC2024-Spring)*, pp. 1–7, 2024. <https://doi.org/10.1109/VTC2024-Spring62846.2024.10683485>
- 152.Y. Jimenez, C. Cervello-Pastor, A.J. Garcia, On the controller placement for designing a distributed SDN control layer. In: *2014 IFIP Networking Conf.*, pp. 1–9, 2014. <https://doi.org/10.1109/IFIPNetworking.2014.6857117>
- 153.M. Junger, T. Liebling, D. Naddef, G. Nemhauser, W. Pulleyblank, G. Reinelt, G. Rinaldi, L. Wolsey (eds), *50 Years of Integer Programming 19582008. From the Early Years to the State-of-the-Art*. Springer, 2010. <https://doi.org/10.1007/978-3-540-68279-0>
- 154.M.M. Kazemian, M. Mirabi, Controller placement in software defined networks using multi-objective antlion algorithm. *J. of Supercomputing*, 78, 5626–5649, 2022. <https://doi.org/10.1007/s11227-021-04109-4>
- 155.M. Khijand, K. Majidzadeh, M. Masdari, Y. Farhang, Controller placement in SDN using game theory and a discrete hybrid metaheuristic algorithm. *J. of Supercomput.*, 80, 6552–6600, 2024. <https://doi.org/10.1007/s11227-023-05709-y>
- 156.M. Khorramizadeh, V. Ahmadi, Capacity and load aware software defined network controller placement in heterogeneous environments. *Comput. Commun.*, 129, 226–247, 2018. <https://doi.org/10.1016/j.comcom.2018.07.037>
- 157.S. Khuller, Y.J. Sussmann, The capacitated K -center problem. *SIAM J. on Discr. Math.*, 13(3), 403–418, 2000. <https://doi.org/10.1137/S0895480197329776>
- 158.B.P.R. Killi, S.V. Rao, Optimal model for failure foresight capacitated controller placement in software defined networks. *IEEE Commun. Lett.*, 20(6), 1108–1111, 2016. <https://doi.org/10.1109/LCOMM.2016.2550026>
- 159.B.P.R. Killi, S.V. Rao, Capacitated next controller placement in software defined networks. *IEEE Trans. Netw. Serv. Manag.*, 14(3), 514–527, 2017. <https://doi.org/10.1109/TNSM.2017.2720699>
- 160.B.P.R. Killi, E.A. Reddy, S.V. Rao, Cooperative game theory based network partitioning for controller placement in SDN. In: *Proc. 10th Int. Conf. Commun. Syst. Netw. (COMSNETS)*, pp. 105–112, 2018. <https://doi.org/10.1109/COMSNETS.2018.8328186>

- 161.B.P.R. Killi, S.V. Rao, Towards improving resilience of controller placement with minimum backup capacity in software defined networks. *Computer Communications*, 149, 102–114, 2019. <https://doi.org/10.1016/j.comnet.2018.11.027>
- 162.B.P.R. Killi, S.V. Rao, Controller placement in software defined networks: a comprehensive survey. *Computer Communications*, 163, art. 106883, 2019. <https://doi.org/10.1016/j.comnet.2019.106883>
- 163.B.R. Killi, S.V. Rao, Poly-stable matching based scalable controller placement with balancing constraints in SDN. *Computer Communications*, 154, 82–91, 2020. <https://doi.org/10.1016/j.comcom.2020.02.053>
- 164.H. Kim, N. Feamster, Improving network management with software defined networking. *IEEE Commun. Mag.*, 51(2), 114–119, 2013. <https://doi.org/10.1109/MCOM.2013.6461195>
- 165.D.I. Kim, E.-H. Shin, M.S. Jin, Hierarchical power control with interference allowance for uplink transmission in two-tier heterogeneous network. *IEEE Trans. on Wir. Commun.*, 14(2), 616–627, 2015.
- 166.L.J. Kim, F. Phillipson, R.S. Wezeman, A multi-service capacitated facility location problem with stochastic demand. In: F. Phillipson, G. Eichler, C. Erfurth, G. Fahrberger (eds), *Innovations for Community Services I4CS 2022*, pp. 199–214, 2022. <https://doi.org/10.1007/978-3-031-06668-9>
- 167.H.I. Kobo, A.M. Abu-Mahfouz, G.P. Hancke, A survey on software-defined wireless sensor networks: challenges and design requirements. *IEEE Access*, 5, 1871–1899, 2017. <https://doi.org/10.1109/ACCESS.2017.2666200>
- 168.A. Korman, S. Kutten, Controller and estimator for dynamic networks. *Information and Computation*, 223, 43–66, 2013. <https://doi.org/10.1016/j.ic.2012.10.018>
- 169.S. Kouhbor, J. Ugon, A. Kruger, A. Rubinov, P. Branch, Optimal placement of access point in WLAN based on a new algorithm. In: *Proc. of the Int. Conf. on Mobile Business (ICMB'05)*, pp. 592–598, 2005. <https://doi.org/10.1109/ICMB.2005.75>
- 170.D. Kreutz, F.M.V. Ramos, P.E. Verissimo, C.E. Rithenberg, S. Azodolmolky, S. Uhlig, Software-defined networking: a comprehensive survey. *Proc. of the IEEE*, 103(1), 14–76, 2015. <https://doi.org/10.1109/JPROC.2014.2371999>
- 171.A. Ksentini, M. Bagaa, T. Taleb, On using SDN in 5G: the controller placement problem. In: *Proc. 2016 IEEE Global Communications Conf. GLOBECOM*, pp. 1–6, 2016. <https://doi.org/10.1109/GLOCOM.2016.7842066>
- 172.N. Ku, S. Ha, M.-I. Roh, Design of controller for mobile robot in welding process of shipbuilding engineering. *J. of Computational Design and Engineering*, 1(4), 243–255, 2014. <https://doi.org/10.7315/JCDE.2014.024>
- 173.H. Kuang, Y. Qiu, R. Li, X. Liu, A hierarchical k -means algorithm for controller placement in SDN-based WAN architecture. In: *2018 10th Int. Conf. on Measuring Technology and Mechatronics Automation (ICMTMA)*, pp. 263–267, 2018. <https://doi.org/10.1109/ICMTMA.2018.00070>
- 174.A. Kumari, A.S. Sairam, A survey of controller placement problem in software defined networks. *Electr. prepr.*, 32 p., May 19, 2019. <https://doi.org/10.48550/arXiv.1905.04649>
- 175.Y. Kyung, J. Park, Prioritized admission control with load distribution over multiple controllers for scalable SDN-based mobile networks. *Wireless Netw.*, 25, 2963–2976, 2019. <https://doi.org/10.1007/s11276-017-115-x>
- 176.S. Lange, S. Gebert, T. Zinner, P. Tran-Gia, D. Hock, M. Jarschel, M. Hoffmann, Heuristic approaches to the controller placement problem in large scale SDN networks. *IEEE Trans. on Network and Service Management*, 12(1), 4–17, 2015. <https://doi.org/10.1109/TNSM.2015.2402432>
- 177.D. Lee, W. Lee, J. Kim, Genetic algorithmic topology control for two-tiered wireless sensor networks. *Computational Science-ICCS*, 2007, Springer, pp. 385–392, 2007. <https://doi.org/10.1007/978-3-540-72590-9>
- 178.S. Lee, S. Lee, K. Kim, Y.H. Kim, Base station placement algorithm for large-scale LTE heterogeneous networks. *PLoS ONE*, 10(10), e0139190, 1–19, 2015. <https://doi.org/10.1371/journal.pone.0139190>
- 179.M.Sh. Levin, *Modular System Design and Evaluation*. Springer, 2015. <https://doi.org/10.1007/978-3-319-09876-0>
- 180.M.Sh. Levin, Towards combinatorial clustering: preliminary research survey. *Electr. prepr.*, 102 p., May 28, 2015. <https://doi.org/10.48550/arXiv.1505.07872>
- 181.M.Sh. Levin, On combinatorial clustering: literature review, methods, examples. *J. of Commun.*

- Technol. and Electronics, 60(12), 1403–1428, 2015. <https://doi.org/10.1134/S1064226915120177>
- 182.M.Sh. Levin, Note on dominating set problems. *J. of Communications Technology and Electronics*, 66(Suppl. 1), S8-S22, 2021. <https://doi.org/10.1134/S1064226921130040>
- 183.M.Sh. Levin, On the clique partitioning of a graph. *J. of Communications Technology and Electronics*, 67(S2), S267–S274, 2022.
- 184.M.Sh. Levin, Combinatorial clustering engineering in communications: preliminary survey. Preprint, 140 p., Nov 6, 2024. <https://doi.org/10.13140/RG.2.2.33224.70401>
- 185.M.Sh. Levin, Engineering note on p -center problems: preliminary material. Preprint. 51 p., Oct. 2025. (ResearchGate) <https://doi.org/10.13140/RG.2.2.26105.94568>
- 186.M.Sh. Levin, p -center problem. *J. of Communications Technology and Electronics*, 70(7), 370-387, 2025. <https://doi.org/10.1134/S1064226925700457>
- 187.F. Li, Y. Wang, X.Y. Li, A. Nusairat, Y. Wu, Gateway placement for throughput optimization in wireless mesh networks. *Mobile Netw. Appl.*, 13(1–2), 198–211, 2008. <https://doi.org/10.1007/s11036-008-0034-8>
- 188.J. Li, L. Andrew, C. Foh, M. Zukerman, H.-H. Chen, Connectivity, coverage and placement in wireless sensor networks. *Sensors*, 9(10), 7664-7693, 2009. <https://doi.org/10.3390/s91007664>
- 189.N. Li, J.-F. Martinez-Ortega, L.L. Santidrian, J.M. Chaus, Probability model based energy efficient and reliable topology control algorithm. *Energies*, 9(10), art. 841, 1–17, 2016. <https://doi.org/10.3390/en9100841>
- 190.N. Li, B. Curuklu, J. Bastos, V. Sucasas, J. Fernandez, J. Rodriguez, Probabilistic and highly efficient topology control algorithm for underwater cooperating AUV networks. *Sensors*, 17(5), art. 1022, 1–23, 2017. <https://doi.org/10.3390/s17051022>
- 191.Z. Li, Y. Li, T. Yuan, S. Chen, S. Jiang, Chemical reaction optimization for virtual machine placement in cloud computing. *Appl. Intell.*, 49(1), 220-232, 2019. <https://doi.org/10.1007/s10489-018-1264-5>
- 192.Y. Li, S. Guan, C. Zhang, W. Sun, Parameter optimization model of heuristic algorithms for controller placement in large-scale SDN. *IEEE Access*, 8, 151668–151680, 2020. <https://doi.org/10.1109/ACCESS.2020.3017673>
- 193.C. Li, K. Jiang, Y. Luo, Dynamic placement of multiple controllers based on SDN and allocation of computational resources based on heuristic ant colony algorithm. *KBS*, 241, art. 108330, 2022. <https://doi.org/10.1016/j.knosys.2022.108330>
- 194.C. Li, J. Liu, N. Ma, Q. Zhang, Z. Zhong, L. Jiang, G. Jia, Deep reinforcement learning based controller placement and optimal edge selection in SDN-based multi-access edge computing environments. *J. of Parallel and Distr. Comput.*, 193, art. 104948, 2024. <https://doi.org/10.1016/j.jpdc.2024.104948>
- 195.W. Liang, C. Ma, M. Zheng, L. Luo, Relay node placement in wireless sensor networks: from theory to practice. *IEEE Trans. on Mobile Computing*, 20(4), 1602–1613, 2021. <https://doi.org/10.1109/TMC.2019.2962674>
- 196.J. Liao, H. Sun, J. Wang, Q. Qi, K. Li, T. Li, Density cluster based approach for controller placement problem in large-scale software defined networking. *Comput. Netw.*, 112(15), 24–35, 2017. <https://doi.org/10.1016/j.comnet.2016.10.014>
- 197.L. Liao, V.C. Leung, Genetic algorithms with particle swarm optimization based mutation for distributed controller placement in SDNs. In: *Proc. IEEE Conf. Netw. Function Virtualization Softw. Defined Netw. (NFV-SDN)*, pp. 1–6, 2017. <https://doi.org/10.1109/NFV-SDN.2017.8169836>
- 198.Z. Liao, C. Chen, Y. Ju, C. He, J. Jiang, Q. Pei, Multi-controller deployment in SDN-enabled 6G space-air-ground integrated network. *Remote Sensing*, 14(5), art. 1076, 1–29, 2022. <https://doi.org/10.3390/rs14051076>
- 199.N. Lin, Q. Zhao, L. Zhao, A. Hawbani, L. Liu, G. Min, A novel cost-effective controller placement scheme for software-defined vehicular networks. *IEEE Internet of Things J.*, 8(18), 14080–14093, 2021. <https://doi.org/10.1109/JIOT.2021.3069878>
- 200.G. Lintern, P.N. Kugler, Sociotechnical system safety: hierarchical control versus mindfulness. *Systems Engineering*, 20(4), 307–317, 2017. <https://doi.org/10.1002/sys.21396>
- 201.S. Liu, L. Lazos, M. Krunz, Cluster-based control channel allocation in opportunistic cognitive radio networks. *IEEE Trans. Mobile Comput.*, 11(10), 1436–1449, 2012. <https://doi.org/10.1109/TMC.2012.33>
- 202.Q. Liu, Z. Zhang, The analysis of coverage probability, ASE and EE in heterogeneous ultra-

- dense networks with power control. *Digital Communications and Networks*, 6(4), 524–533, 2020. <https://doi.org/10.1016/j.dcan.2020.02.002>
- 203.K.S.K. Liyanage, M. Ma, P.H.J. Chong, Controller placement optimization in hierarchical distributed software defined vehicular networks. *Computer Networks*, 135, 226–239, 2018. <https://doi.org/10.1016/j.comnet.2018.02.022>
- 204.Y.P. Llerena, P.R.L. Gondim, SDN-controller placement for D2D communications. *IEEE Access*, 7, 169745–169761, 2019. <https://doi.org/10.1109/ACCESS.2019.2955434>
- 205.E.L. Lloyd, R. Liu, M.V. Marathe, R. Ramanathan, S.S. Ravi, Algorithmic aspects of topology control problems for Ad Hoc networks. *Mobile Networks and Applications*, 10(1–2), 19–34, 2005. <https://doi.org/10.1023/B:MON.0000048543.95178.f5>
- 206.E. Lloyd, G. Xue, Relay node placement in wireless sensor networks. *IEEE Trans. on Computers*, 56(1), 134–138, 2007. <https://doi.org/10.1109/TC.2007.250629>
- 207.B.F. Lo, A survey of common control channel design in cognitive radio networks. *Physical Communication*, 4(1), 26–39, 2011. <https://doi.org/10.1016/j.phycom.2010.12.004>
- 208.L. LoBello, E. Toscano, An adaptive approach to topology management in large and dense real-time wireless sensor networks. *IEEE Trans. Industrial Informatics*, 5(3), 314–324, 2009. <https://doi.org/10.1109/TII.2009.2025656>
- 209.J. Lu, Z. Zhang, T. Hu, Spectral clustering based approach for controller placement problem in software defined networking. *J. of Physics, Conf. Series*, 1087, art. 042073, 1–8, 2018. <https://doi.org/10.1088/1742-6596/1087/4/042073>
- 210.J. Lu, Z. Zhang, T. Hu, P. Yi, J. Lan, A survey of controller placement problem in software-defined networking. *IEEE Access*, 7, 24290–24307, 2019. <https://doi.org/10.1109/ACCESS.2019.2893283>
- 211.M. Luo, Y. Zeng, J. Li, W. Chou, An adaptive multi-path computation framework for centrally controlled networks. *Comp. Netw.*, 83, 30–44, 2015. <https://doi.org/10.1016/j.comnet.2015.02.004>
- 212.D.K. Luong, Y.-F. Hu, J.-P. Li, F. Benamrane, M. Ali, K. Abdo, Traffic-aware dynamic controller placement using AI techniques in SDN-based aeronautical networks. In: 2019 IEEE/AIAA Digital Avionic Systems Conf. (DASC), pp. 1–8, 2019. <https://doi.org/10.1109/DASC43569.2019.9081810>
- 213.Y.-W. Ma, J.-L. Chen, Y.-H. Tsai, K.-H. Cheng, W.-C. Hung, Load-balancing multiple controllers mechanism for software-defined networking. *Wireless Personal Communications*, 94(4), 3549–3574, 2016. <https://doi.org/10.1007/s11277-016-3790-y>
- 214.C. Ma, W. Liang, M. Zheng, X. Xia, L. Chen, A Voronoi diagram and Q-learning based relay node placement method subject to radio irregularity, *ACM Trans. on Sensor Networks*, 20(1), art. 13, 13:1–13:27, 2024. <https://doi.org/10.1145/3617124>
- 215.M. Mao, P. Yi, L. Hou, W. Zhao, A controller-based roadside unit plane architecture for software-defined internet of vehicles. *Cluster Computing*, 27(2), 1235–1249, 2024. <https://doi.org/10.1007/s10586-023-04007-9>
- 216.S. Martinez, F. Bullob, Optimal sensor placement and motion coordination for target tracking. *Automatica*, 42(4), 661–668, 2006. <https://doi.org/10.1016/j.automatica.2005.12.018>
- 217.P.S. Marwein, D. Kandar, An internet of vehicles model based on hierarchical controllers. In: B. Sharma, D.T. Do, S.N. Sur, C.M. Liu (eds), *Advances in Communication, Devices and Networking ICCDN 2024*, LNEE 1233, Springer, pp. 275–284, 2025. <https://doi.org/10.1007/978-981-97-5337-6>
- 218.R. Mathar, T. Niessen, Optimum positioning of base stations for cellular radio networks. *Wireless networks*, 6(6), 421–428, 2000. <https://doi.org/10.1023/A:1019263308849>
- 219.V. Milanés, J. Villagra, J. Godoy, J. Simo, J. Perez, E. Inoeva, An intelligent V2I-based traffic management system. *IEEE Trans. on Intelligent Transportation Systems*, 13(1), 49–58, 2012. doi: 10.1109/TITS.2011.2178839
- 220.B.G. Mirkin, *Clustering for Data Mining: A Data Recovery Approach*. Chapman & Hall/CRC, Boca Raton, FL, 2005. <https://doi.org/10.1201/9781420034912>
- 221.S. Misra, S.D. Hong, G. Xue, J. Tang, Constrained relay node placement in wireless sensor networks: formulation and approximations. *IEEE/ACM Trans. on Networking*, 18(2), 434–447, 2010. <https://doi.org/10.1109/TNET.2009.2033273>
- 222.V.K. Mohan Raj, R. Sriram, Power management in virtualized datacenter - a survey. *J. Netw. Comput. App.*, 69, 117–133, 2016. <https://doi.org/10.1016/j.jnca.2016.04.019>
- 223.S. Mohanty, K. Kanodia, B. Sahoo, K. Kurroliya, A simulated annealing strategy for reliable controller

- placement in software defined networks. In: 2020 7th Int. Conf. on Signal Processing and Integrated Networks (SPIN), pp. 844–849, 2020. <https://doi.org/10.1109/SPIN48934.2020.9071317>
- 224.S. Mohanty, B. Sahoo, S.S. Behera, An assessment of nature-inspired metaheuristic algorithms for resilience controller placement in software-defined networks. *Decision Analytics J.*, 12, art. 100501, 1–18, 2024. <https://doi.org/10.1016/j.dajour.2024.100501>
- 225.H. Mojtez, H. Kamel, R. Zanjani, A.M. Bidgoli, Controller placement issues in software-defined networks with different goals: a comprehensive survey. *The J. of Supercomputing*, 80(13), 19127–19209, 2024. <https://doi.org/10.1007/s11227-024-06230-6>
- 226.H. Mokhtar, X. Di, Z. Jiang, M. Hamdan, Dynamic controller assignment in LEO satellite based SDN using multi-agent deep reinforcement learning. In: 2024 IEEE Conf. on Standards for Communications and Networking (CSCN), pp. 208–211, 2024. <https://doi.org/10.1109/CSCN63874.2024.10849764>
- 227.A. Mosa, N.W. Paton, Optimizing virtual machine placement for energy and SLA in clouds using utility functions. *J. of Cloud Computing*, 5, art. 17, 1–17, 2016. <https://doi.org/10.1186/s13677-016-0067-7>
- 228.S. Muppala, X. Zhou, Coordinated session-based admission control with statistical learning for multi-tier internet applications. *J. of Netw. and Comp. Appl.*, 34(1), 20–29, 2011. <https://doi.org/10.1016/j.jnca.2010.10.007>
- 229.S. Narasimhan, Locating concentrators in a computer network with multiple coverage for terminals. *Computer Communications*, 17(2), 94–102, 1994. [https://doi.org/10.1016/S0140-3664\(05\)80014-3](https://doi.org/10.1016/S0140-3664(05)80014-3)
- 230.A.N. Njoya, C. Thron, J. Barry, W. Abdou, E. Tonye, N. Siri Lawrence Konje, A. Dipanda, Efficient scalable sensor node placement algorithm for fixed target coverage applications of wireless sensor networks. *IET Wireless Sensor Systems*, 7(2), 44–54, 2017. <https://doi.org/10.1049/iet-wss.2016.0076>
- 231.M. Oguchi, R. Hara, A speculative control mechanism of cloud computing systems based on emergency disaster information using SDN. *Procedia CS*, 98, 515–521, 2016. <https://doi.org/10.1016/j.procs.2016.09.065>
- 232.H. Okamura, S. Miyata, T. Dohi, A Markov decision process approach to dynamic power management in a cluster system. *IEEE Access*, 3, 3039–3047, 2015. <https://doi.org/10.1109/ACCESS.2015.2508601>
- 233.Y.E. Oktian, S. Lee, H. Lee, J. Lam, Distributed SDN controller system: a survey on design choice. *Computer Networks*, 121, 100–111, 2017. <https://doi.org/10.1016/j.comnet.2017.04.038>
- 234.J. Pan, Y.T. Hon, L. Cai, Y. Shi, S.X. Shen, Topology control for wireless sensor networks. In: *Proc. ACM MobiCom*, pp. 286–299, 2003. <https://doi.org/10.1145/938985.939015>
- 235.C.M. Papadimitriou, K. Steiglitz, *Combinatorial Optimization: Algorithms and Complexity*. Dover, 1998. ISBN 0486402584.
- 236.P.M. Pardalos, L. Pitsoulis (Eds.), *Nonlinear Assignment Problems*. Springer, 2000. <https://doi.org/10.1007/978-1-4757-3155-2>
- 237.E. Park, S.-R. Lee, I. Lee, Antenna placement optimization for distributed antenna systems. *IEEE Trans. on Wireless Communications*, 11(7), 2468–2477, 2012. <https://doi.org/10.1109/TWC.2012.051712.110670>
- 238.J. Park, J. Ha, B.B. Kang, M. Kim, MoHoP: a protocol providing for both mobility management and host privacy. *Computer Networks*, 148, 20–33, 2019. <https://doi.org/10.1016/j.comnet.2018.10.014>
- 239.M. Penn, T. Raviv, Optimizing the quality control station configuration. *Naval Research Logistics*, 54(3), 301–314, 2007. <https://doi.org/10.1002/nav.20206>
- 240.M. Penn, T. Raviv, A polynomial time algorithm for solving a quality control station configuration problem. *Discr. Appl. Math.*, 156(4), 412–419, 2008. <https://doi.org/10.1016/j.dam.2007.08.005>
- 241.J. Perez, V. Milanés, J. Godoy, J. Villagra, E. Onieva, Cooperative controllers for highway based on human experience. *ESwA*, 40, 1024–1033, 2013. <https://doi.org/10.1016/j.eswa.2012.08.011>
- 242.N. Perrot, T. Reynaud, Optimal placement of controllers in a resilient SDN architecture. In: 2016 12th Int. Conf. on the Design of Reliable Communication Networks (DRCN), pp. 145–151, 2016. <https://doi.org/10.1109/DRCN.2016.7470849>
- 243.O.Y. Pershin, A.A. Mukhtarov, V.M. Vishnevsky, A.A. Larionov, Optimal placement of base stations in integrated design of wireless networks. *Programming and Computer Software*, 49(Suppl 2), S82–S90, 2023. <https://doi.org/10.1134/S0361768823100055>
- 244.S. Petale, J. Thangaraj, Failure-based controller placement in software defined networks. *IEEE Trans. on Networking*, 17(1), 503–516, 2020. <https://doi.org/10.1109/TNSM.2019.2949256>

- 245.H. Pirkul, V. Nagarajan, Locating concentrators in central computer networks. *Ann. of Oper. Res.*, 36, 247–261, 1992. <https://doi.org/10.1007/BF02094332>
- 246.E. Pluzhnik, E. Nikulchev, S. Payain, Optimal control of applications for hybrid cloud services. *Inl. IEEE 10th World Congress on Services (Services2014)*, pp. 458–461, 2014. <https://doi.org/10.1109/SERVICES.2014.88>
- 247.A. Ponraj, Optimistic virtual machine placement in cloud data centers using queuing approach. *FGCS*, 93, 338–344, 2019. <https://doi.org/10.1016/j.future.2018.10.022>
- 248.K. Poularakis, J. Llorca, A.M. Tulino, L. Tassiulas, Service placement and request routing in MEC networks with storage, computation, and communication constraints. *IEEE/ACM Trans. Netw.*, 28(3), 1047–1060, 2020. <https://doi.org/10.1109/TNET.2020.2980175>
- 249.T. Pradeesha, R. Raju, V.S.K. Venkatachalapathy, P. Raja, An effective of bio-inspired multiverse optimization based controller placement in software defined network environment. *Int. J. Inf. Technol.* 17, 2035–2048, 2025. <https://doi.org/10.1007/s41870-025-02434-y>
- 250.M. Priyadarsini, J.C. Mukherjee, P. Bera, S. Kumar, A.H.M. Jakaria, M. Ashiqur Rahman, An adaptive load balancing scheme for software-defined network controllers. *Computer Networks*, 164, art. 106918, 2019. <https://doi.org/10.1016/j.comnet.2019.106918>
- 251.D. Qi, S. Shen, G. Wang, Towards an efficient VNF placement in network function virtualization. *Computer Communications*, 138, 81–89, Apr. 2019. <https://doi.org/10.1016/j.comcom.2019.03.005>
- 252.Q. Qin, K. Poularakis, G. Iosifidis, S. Kompella, L. Tassiulas, SDN controller placement with delay-overhead balancing in wireless edge networks. *IEEE Trans. on Network and Service Management*, 15(4), 1446–1459, 2018. <https://doi.org/10.1109/TNSM.2018.2876064>
- 253.Y. Qin, H. Wang, S. Yi, X. Li, L. Zhai, Virtual machine placement based on multi-objective reinforcement learning. *Appl. Intell.*, 50(8), 2370–2384, 2020. <https://doi.org/10.1007/s10489-020-01633-3>
- 254.C. Qiu, C. Zhao, F. Xu, T. Yang, Sleeping mode of multi-controller in green software defined networking. *EURASIP J. on Wireless Communications and Networking*, 282, 1–9, 2016. <https://doi.org/10.1186/s13638-016-0779-x>
- 255.C. Quadri, V. Mancuso, M.A. Marsan, G.P. Rossi, Edge-based platoon control. *Comput. Commun.*, 181, 17–31, 2022. <https://doi.org/10.1016/j.comcom.2021.09.021>
- 256.D.E. Quevedo, K.H. Johansson, A. Ahlen, I. Jurado, Adaptive controller placement for wireless sensor-actuator networks with erasure channels. *Automatica*, 49(11), 3458–3466, 2013. <https://doi.org/10.1016/j.automatica.2013.08.024>
- 257.N.S. Radam, S.T.F. Al-Janabi, K.Sh. Jasim, Multi-controllers placement optimization in SDN by the hybrid HSA-PSO algorithm. *Computers*, 11(7), art. 111, 1–26, 2022. <https://doi.org/10.3390/computers11070111>
- 258.N.S. Radam, S.T. Faraj Al-Janabi, K.Sh. Jasim, Using metaheuristics (SA-MCSDN) optimizer for multi-controller placement in software-defined networking. *Future Internet*, 15(1), art. 39, 1–21, 2023. <https://doi.org/10.3390/fi15010039>
- 259.L. Raisanen, R.M. Whitaker, Comparison and evaluation of multiple objective genetic algorithms for the antenna placement problem. *Mobile Networks and Applications*, 10(1–2), 79–88, 2005. <https://doi.org/10.1023/B:MONE.0000048547.84327.95>
- 260.R. Rajaraman, Topology control and routing in Ad Hoc networks: a survey. *ACM SIGACT News*, 33(2), 66–73, 2002. <https://doi.org/10.1145/564585.564602>
- 261.R. Ramar, R. Shanmugasundaram, Connected k -coverage topology control for area monitoring in wireless sensor networks. *Wireless Pers. Commun.*, 84(2), 1051–1067, 2015. <https://doi.org/10.1007/s11277-015-2675-9>
- 262.P. Ramya, V. Gopalakrishnan, Proficient algorithms for enhancing topology control for dynamic clusters in MANET. *Cluster Computing*, 22, Supplement 4, 59715–59726, 2019. <https://doi.org/10.1007/s10586-017-1410-6>
- 263.K.A. Rasol, J. Domingo-Pascual, Joint placement latency optimization of the control plane. *In: 2020 Int. Symp. on Networks, Computers and Communications (ISNCC)*, pp. 1–6, 2020. <https://doi.org/10.1109/ISNCC49221.2020.9297271>
- 264.K.A. Rasol, J. Domingo-Pascual, Multi-level hierarchical controller placement in software defined networking. *In: B. Ghita, S. Shiaeles (eds), INC 2020, LNNS 2020, Springer*, pp. 131–145, 2021. <https://doi.org/10.1007/978-3-030-64758-2>

- 265.V. Rathod, N. Jeppu, S. Sastry, S. Singala, M.P. Tahiliani, CoCoA++: delay gradient based congestion control for Internet of Things. *FGCS*, 100, 1053–1072, 2019. <https://doi.org/10.1016/j.future.2019.04.054>
- 266.D.B. Rawat, S.R. Lenkala, Software defined networking architecture, security and energy efficiency: a survey. *IEEE Commun. Surv. & Tut.*, 19(1), 325–346, 2014. <https://doi.org/10.1109/COMST.2016.2618874>
- 267.F.J. Ros, P.M. Ruiz, On reliable controller placement on software defined networks. *Comput. Commun.*, 77, 41–51, 2016. <https://doi.org/10.1016/j.comcom.2015.09.008>
- 268.B. Roy, *Multicriteria Methodology for Decision Aiding*. Springer, 1996. <https://doi.org/10.1007/978-1-4757-2500-1>
- 269.S. Roy, D. Bardhan, S. Das, Base station placement on boundary of convex polygon. *J. of Parallel and Distributed Computing*, 68(2), 265–273, 2008. <https://doi.org/10.1016/j.jpdc.2007.08.005>
- 270.K. Saeed, M.O. Ullah, Toward reliable controller placements in software-defined network using constrained multiobjective optimization techniques. *IEEE Access*, 10, 129865–129883, 2022. <https://doi.org/10.1109/ACCESS.2022.3228039>
- 271.D. Saha, P.S. Bhattacharjee, A. Mukherjee, Time efficient heuristics for cell-to-switch assignment in quasi-static/dynamic location area planning of mobile cellular networks. *Computer Communications*, 30, 326–340, 2007. <https://doi.org/10.1016/j.comcom.2006.08.036>
- 272.J. Sahoo, M.A. Salahuddin, R. Glitho, H. Elbiaze, W. Ajib A survey on replica server placement algorithms for content delivery networks. *IEEE Commun. Surv.& Tut.*, 19(2), 1002–1026, 2017. <https://doi.org/10.1109/COMST.2016.2626384>
- 273.K.S. Sahoo, D. Puthal, M.S. Obaidat, A. Sarkar, S.K. Mishra, B. Sahoo, On the placement of controllers in software-defined WAN using meta-heuristic approach. *J. of Systems and Software*, 145, 180–194, 2018. <https://doi.org/10.1016/j.jss.2018.05.032>
- 274.R. Sakthivel, M. Joby, S. Marshal Anthoni, Resilient dissipative based controller for stochastic systems with randomly occurring gain fluctuations. *Inf. Sci.*, 418–419, 447–462, 2017. <https://doi.org/10.1016/j.ins.2017.08.025>
- 275.R. Salam, A. Bhattacharya, Efficient greedy heuristic approach for fault-tolerant distributed controller placement in scalable SDN architecture. *Cluster Comput.*, 25, 4543–4572, 2022. <https://doi.org/10.1007/s10586-022-03694-0>
- 276.S. Salcedo-Sanz, J.A. Portilla-Figueras, E.G. Ortiz-Garcia, A.M. Perez-Bellido, C. Thaves, A. Fernandez-Anta, X. Yao, Optimal switch location in mobile communication networks using hybrid genetic algorithms. *Appl. Soft Comput.*, 8(4), 1486–1497, 2008. <https://doi.org/10.1016/j.asoc.2007.10.021>
- 277.A. Sallahi, M. St-Hilaire, Optimal model for the controller placement problem in software defined networks. *IEEE Commun. Lett.*, 19(1), 30–33, 2015. <https://doi.org/10.1109/LCOMM.2014.2371014>
- 278.N. Samaan, A. Karmouch, Towards autonomic network management: an analysis of current and future research directions. *IEEE Commun. Surv. & Tut.*, 11(3), 22–36, 2009. <https://doi.org/10.1109/SURV.2009.090303>
- 279.Sandhya, Y. Sinha, K. Haribabu, A survey: hybrid SDN. *J. of Network and Computer Applications*, 100, 35–55, 2017. <https://doi.org/10.1016/j.jnca.2017.10.003>
- 280.D. Santos, A. de Sousa, C.M. Machuca, The controller placement problem for robust SDNs against malicious node attacks considering the control plane with and without split-brain. *Ann. Telecommun.*, 74, 575–591, 2019. <https://doi.org/10.1007/s12243-019-00725-7>
- 281.A.B. Sapkota, B.B.R. Dawadi, C.S.R. Joshi, Multi-controller placement optimization using naked mole-rat algorithm over software-defined networking environment. *J. of Computer Networks and Communications*, Art. ID 3145276, 1–18, 2022. <https://doi.org/10.1155/2022/3145276>
- 282.B. Sapkota, B.R. Dawadi, S.R. Joshi, Controller placement problem during SDN deployment in ISP/Telco networks: a survey. *Engineering Reports*, 6(2), art. e12801, 1–28, 2024. <https://doi.org/10.1002/eng2.12801>
- 283.B. Sapkota, B.R. Dawadi, S.R. Joshi, G. Karn, Traffic-driven controller-load-balancing over multi-controller software-defined networking environment. *Network*, 4, 523–544, 2024. <https://doi.org/10.3390/network4040026>
- 284.D. Sauter, Co-design of safe networked control systems. *IFAC Proceedings Volumes*, 45(20), 1215–

- 1224, 2012. <https://doi.org/10.3182/20120829-3-MX-2028.00297>
- 285.D. Schweitzer, H. Medal, Wireless LAN transmitter location under the threat of jamming attacks. *Comp. and Oper. Res.*, 106, 14–27, 2019. <https://doi.org/10.1016/j.cor.2019.01.014>
- 286.A. Schrijver, *Theory of Linear and Integer Programming*. Wiley, 1998. ISBN: 978-0-471-98232-6
- 287.M. Schwartz, *Computer-Communication Network Design and Analysis*. Prentice-Hall, 1977. ISBN-13: 978-0131651340
- 288.S. Seetha, S.A.J. Francis, E.G.M. Kanaga, Optimal placement techniques of mesh router nodes in wireless mesh networks. In: A. Haidorai, A. Ramu, S. Mohanram, M.Y. Chen (eds), 2nd EAI Int. Conf. on Big Data Innovation for Sustainable Cognitive Computing. Springer, pp. 217–226, 2021. <https://doi.org/10.1007/978-3-030-47560-4>
- 289.I. Selinis, K. Katsaros, S. Vahid, R. Tafazolli, Damysus: a practical IEEE 802.11ax color aware rate control algorithm. *Int. J. of Wireless Information Networks*, 26(1), 285–307, 2019. <https://doi.org/10.1007/s10776-019-00439-6>
- 290.S.H. Shah, K. Chen, K. Nahrstedt, Dynamic bandwidth management in single-hop Ad Hoc wireless networks. *Mobile Networks and Applications*, 10(1–2), 199–217, 2005. <https://doi.org/10.1023/B:MONE.0000048555.72514.9a>
- 291.S.A. Shah, J. Fiz, M. Farooq, A. Shafi, S.A. Mehdi, An architectural evaluation of SDN controllers. In: *Proc. of the IEEE Int. Conf. on Communications*, pp. 3504–3508, 2013. <https://doi.org/10.1109/ICC.2013.6655093>.
- 292.R. Shah, M. Vutukuru, P. Kulkarni, Cuttlefish: hierarchical SDN controllers with adaptive offload. In: 2018 IEEE 26th Int. Conf. on Network Protocols (ICNP), pp. 198–208, 2018. <https://doi.org/10.1109/ICNP.2018.00029>.
- 293.A. Shenfield, P.J. Fleming, Multiobjective evolutionary design of robust controllers on the grid. *Eng. Appl. of AI*, 27, 17–27, 2014. <https://doi.org/10.1016/j.engappai.2013.09.015>
- 294.A. Shirmarz, A. Ghaffari, Taxonomy of controller placement problem (CPP) optimization in Software Defined Network (SDN): a survey. *J. of Ambient Intelligence and Humanized Computing*, 12, 10473–10498, 2021. <https://doi.org/10.1007/s12652-020-027-w>
- 295.S. Siddiqui, S. Hameed, S.A. Shah, I. Ahmad, A. Aneiba, D. Draheim, S. Dustdar, Toward software-defined networking-based IoT frameworks: a systematic literature review, taxonomy, open challenges and prospects. *IEEE Access*, 10, 70850–70901, 2022. <https://doi.org/10.1109/ACCESS.2022.3188311>
- 296.A.K. Singh, S. Srivastava, A survey and classification of controller placement problem in SDN. *Int. J. Netw. Manage.*, 28(3), e2018, 2018. <https://doi.org/10.1002/nem.2018>
- 297.A.K. Singh, N. Kumar, S. Srivastava, PSO and TLBO based reliable placement of controllers in SDN. *Int. J. Comput. Netw. Inf. Secur.*, 11(2), 36–42, 2019. <http://doi.org/10.5815/ijenis.2019.02.05>
- 298.A.K. Singh, S. Maurya, S. Srivastava, Varna-based optimization: a novel method for capacitated controller placement problem in SDN. *Front. Comput. Sci.*, 14(3), art. 143402, 1–26, 2020. <https://doi.org/10.1007/s11704-018-7277-8>
- 299.A.K. Singh, S. Maurya, N. Kumar, S. Srivastava, Heuristic approaches for the reliable controller placement problem. *Trans. Emerg. Telecommun. Technol.*, 31(2), art. e3761, 2020. <https://doi.org/10.1002/ett.3761>
- 300.A.K. Singh, S. Srivastava, S. Banerjea, Evaluating heuristic techniques as a solution of controller placement problem in SDN. *J. Ambient. Intell. Humaniz. Comput.*, 14, 11729–11746, 2023. <https://doi.org/10.1007/s12652-022-03733-z>
- 301.G.D. Singh, V. Tripathi, A. Dumka, R.S. Rathore, M. Bajaj, J. Escorcía-Gutierrez, N.O. Aljehane, V. Blazek, L. Prokop, A novel framework for capacitated SDN controller placement: balancing latency and reliability with PSO algorithm. *Alexandria Engineering J.*, 87, 77–92, 2024. <https://doi.org/10.1016/j.aej.2023.12.018>
- 302.G.D. Singh, V. Tripathi, A. Dumka, T. Yang, R.S. Rathore, Optimizing controller placement in software defined network: a capacitated and latency-aware approach. *J. of Communications*, 20(3), 272–281, 2025. <https://doi.org/10.12720/jcm.20.3.272-281>
- 303.O. Skarlat, M. Nardelli, S. Schulte, M. Borkowski, P. Leitner, Optimized IoT service placement in the Fog. *Service Oriented Computing and Applications*, 11(4), 427–443, 2017. <https://doi.org/10.1007/s11761-017-0219-8>
- 304.S.K. Somov, The problem of the optimal placing of the information-technological reserve

- in distributed data processing systems. *Aut. and Rem. Control*, 80(6), 1123–1133, 2019. <https://doi.org/10.1134/S0005117919060109>
- 305.B. Sonkoly, J. Czentye, M. Szalay, B. Nemeth, L. Toka, Survey on placement methods in edge and beyond. *IEEE Commun. Surv. & Tut.*, 23(4), 2590–2590, 2021. <https://doi.org/10.1109/COMST.2021.3101460>
- 306.V. Srivastava, R.S. Pandey, Machine intelligence approach: to solve load balancing problem with high quality of service performance for multi-controller based Software Defined Network. *Sustainable Computing: Informatics and Systems*, 30, art. 100511, 1–11, 2021. <https://doi.org/10.1016/j.suscom.2021.100511>
- 307.J.A. Stine, G. de Veciana, Improving energy efficiency of centrally controlled wireless data networks. *Wireless Networks*, 8, 681–700, 2002. <https://doi.org/10.1023/A:1020379326558>
- 308.K. Suh, Y. Guo, J. Kurose, D. Towsley, Locating network monitors: complexity, heuristics, and coverage. *Computer Communications*, 29(10), 1564–1577, 2006. <https://doi.org/10.1016/j.comcom.2005.07.009>
- 309.P. Sun, J. Lan, J. Li, Z. Guo, Y. Hu, Combining deep reinforcement learning with graph neural networks for optimal VMS placement. *IEEE Commun. Lett.*, 25(1), 176–180, 2021. <https://doi.org/10.1109/LCOMM.2020.3025298>
- 310.S. Tahmasebi, N. Rasouli, A.H. Kashefi, E. Rezabeyk, H.R. Faragardi, SYNCOP: an evolutionary multi-objective placement of SDN controllers for optimizing cost and network performance in WSNs. *Computer Networks*, 185, art. 107727, 2021. <https://doi.org/10.1016/j.comnet.2020.107727>
- 311.T. Taleb, M. Bagaa, A. Ksentini, User mobility-aware virtual network function placement for virtual 5G network infrastructure. In: *Proc. of the 2015 IEEE Int. Conf. on Communications (ICC)*, pp. 3879–3884, 2015. <https://doi.org/10.1109/ICC.2015.7248929>
- 312.A. Taneja, S. Rani, S. Garg, M.M. Hassan, S.A. AlQahtani, Energy aware resource control mechanism for improved performance in future green 6G networks. *Computer Networks*, 217, art. 109333, 2022. <https://doi.org/10.1016/j.comnet.2022.109333>
- 313.A.S. Tanenbaum, *Computer Networks*. 4th ed., Prentice Hall PTR, NJ, 2002. ISBN: 0-13-066102-3
- 314.J. Tang, B. Hao, A. Sen, Relay node placement in large scale wireless sensor networks. *Comp. Commun.*, 29(4), 490–501, 2006. <https://doi.org/10.1016/j.comcom.2004.12.032>
- 315.Y. Tang, X. Fang, Deadband scheduling in sensor node and controller node for wireless networked control systems. *Int. J. of Wireless Information Networks*, 25(3), 241–249, 2018. <https://doi.org/10.1007/s10776-018-0384-5>
- 316.M. Tanha, D. Sajjadi, R. Ruby, J. Pan, Capacity-aware and delay-guaranteed resilient controller placement for software-defined WANs. *IEEE Trans. on Network and Service Management*, 15(3), 991–1005, 2018. <https://doi.org/10.1109/TNSM.2018.2829661>
- 317.B.C. Tansel, R.L. Francis, T.J. Lowe, State of the art – location on networks: a survey. Part I: the p -center and p -median problems. *Manag. Science*, 29(4), 482–497, 1983. <https://doi.org/10.1287/mnsc.29.4.482>
- 318.X. Tao, H. Qi, W. Li, K. Li, Y. Liu, Profit-aware scheduling in task-level for datacenter networks. *Computers and Electrical Engineering*, 61, 327–338, 2017. <https://doi.org/10.1016/j.compeleceng.2016.07.013>
- 319.V.S. Thalapala, K. Guravaiah, FCMCP: fuzzy C-means for controller placement in software defined networking. *Procedia CS*, 201, 109–116, 2022. <https://doi.org/10.1016/j.procs.2022.03.017>
- 320.V.S. Thalapala, K. Guravaiah, WOCP controller placement using Whale optimization in SDN-WAN. *Procedia CS*, 252, 883–892, 2025. <https://doi.org/10.1016/j.procs.2025.01.049>
- 321.S. Torkamani-Azar, M. Jahanshani, A new GSO based method for SDN controller placement. *Computer Communications*, 163, 91–108, 2020. <https://doi.org/10.1016/j.comcom.2020.09.004>
- 322.F. Tramarin, A.K. Mok, S. Han, Real-time and reliable industrial control over wireless LANs: algorithms, protocols, and future directions. *Proc. of the IEEE*, 107(6), 1027–1052, 2019. <https://doi.org/10.1109/JPROC.2019.2913450>
- 323.Z. Uykan, R. Jantti, Clustering for determining distributed antenna location in wireless networks. *Wireless Netw.*, 24, 1857–1871, 2018. <https://doi.org/10.1007/s11276-016-1437-2>
- 324.T.H. Vardhan, Y.SriBhargav, J.Anala, K.Yejnakshari Meghana, N. Radhika, A comparative analysis of SDN controller placement problem: IoT-specific tactics and generalized solutions. In:

- 2025 6th Int. Conf. on Recent Advances in Information Technology (RAIT), pp. 1–6, 2025. <https://doi.org/10.1109/RAIT65068.2025.11089072>.
- 325.S. Veeramani, S. Noor Mahammad, An approach to place sink node in a wireless sensor network (WSN). *Wireless Pers. Commun.*, 11, 1117–1127, 2020. <https://doi.org/10.1007/s11277-019-06904-y>
- 326.J.P. VielmaAuthors, Mixed integer linear programming formulation techniques. *SIAM Review*, 57(1), 3–57, 2015. <https://doi.org/10.1137/130915303>
- 327.P.Q. Viet, D. Romero, Aerial base station placement: a tutorial introduction. *IEEE Communications Magazine*, 60(5), 44–49, 2022. <https://doi.org/10.1109/MCOM.001.2100861>.
- 328.H. Vijayaraghavan, J. von Mankowski, C. Mas-Machuca, W. Kellerer, PlaciFi: orchestration optimal 3D access point placement for LiFi-WiFi heterogeneous networks. *IEEE Access*, 11, 115415–115429, 2023. <https://doi.org/10.1109/ACCESS.2023.3325097>
- 329.G.C. Walsh, H. Ye, Scheduling of networked control systems. *IEEE Control Systems Magazine*, 21(1), 57–65, 2001. <https://doi.org/10.1109/37.898792>
- 330.B. Wang, *Coverage Control in Sensor Networks*. Springer, 2010. <https://doi.org/10.1007/978-1-84996-059-5>
- 331.G. Wang, Y. Zhao, J. Huang, Q. Duan, J. Li, A K-means-based network partitioning algorithm for controller placement in software defined networks. In: *Proc. Int. Conf. Commun. (ICC)*, pp. 1–6, 2016. <https://doi.org/10.1109/ICC.2016.7511441> <https://doi.org/10.1109/ICC.2016.7511441>
- 332.G. Wang, Y. Zhao, J. Huang, W. Wang, The controller placement problem in software defined networking: a survey. *IEEE Network*, 31(5), 21–27, 2017. <https://doi.org/10.1109/MNET.2017.1600182>
- 333.Y. Wang, Topology control for wireless sensor networks. In: Y. Li, M.T. Thai, W. WU (eds), *Wireless Sensor Networks and Applications*. Springer, pp. 113–147, 2008. <https://doi.org/10.1007/978-0-387-49592-7>
- 334.X. Wang, P. Zhu, M. Chen, Antenna location design for generalized distributed antenna systems. *IEEE Commun. Lett.*, 13(5), 315–317, 2009. <https://doi.org/10.1109/LCOMM.2009.090123>
- 335.G. Wang, Y. Zhao, J. Huang, Y. Wu, An effective approach to controller placement in software defined wide area networks. *IEEE Trans. on Network and Service Management*, 15(1), 344–355, 2018. <https://doi.org/10.1109/TNSM.2017.2785660>
- 336.X. Wang, H. Zhang, S. Fan, H. Gu, Coverage control of sensor networks in IoT based on RpSO. *IEEE Internet of Things J.*, 5(5), 3521–3532, 2018. <https://doi.org/10.1109/JIOT.2018.2829160>
- 337.Y. Wang, Sink node placement and partial connectivity in wireless sensor networks. *Sensors*, 23(22), art. 9058, 1–23, 2023. <https://doi.org/10.3390/s23229058>
- 338.T. Wang, X. Wang, DeepRP: bottleneck theory guided relay placement for 6G mesh backhaul augmentation. *IEEE Trans. on Mobile Computing*, 24(3), 1744–1758, 2025. <https://doi.org/10.1109/TMC.2024.3487020>
- 339.W. Wen, A dynamic and automatic traffic light control expert system for solving the road congestion problem. *ESwA*, 34(4), 2370–2381, 2008, <https://doi.org/10.1016/j.eswa.2007.03.007>
- 340.H.P. Williams, *Logic and Integer Programming*. Springer, 2009. <https://doi.org/10.1007/978-0-387-92280-5>
- 341.L.A. Wolsey, *Integer Programming*. 2nd ed., Wiley, 2020. ISBN: 978-1-119-60655-0
- 342.J. Wu, Z. Zhang, Y. Hong, Y. Wen, Cloud radio access network (C-RAN): a primer. *IEEE Network*, 29(1), 35–41, 2015. <https://doi.org/10.1109/MNET.2015.7018201>
- 343.F. Xhafa, c. Sanchez, L. Barolli, Local search methods for efficient router nodes placement in wireless mesh networks. *J. Intell. Manuf.*, 23(4), 1293–1303, 2012. <https://doi.org/10.1007/s10845-010-0412-5>
- 344.F. Xia, X. Kong, Z. Xu, Cyber-physical control over wireless sensor and actuator networks with packet loss. In: *Wireless Networking Based Control*, Springer, pp. 85–102, 2010. <https://doi.org/10.1007/978-1-4419-7393-1>
- 345.Y.-Q. Xia, Y.-L. Gao, L.-P. Yan, M.-Y. Fu, Recent progress in networked control systems - a survey. *Int. J. of Automation and Computing*, 12(4), 343–367, 2015. <https://doi.org/10.1007/s11633-015-0894-x>
- 346.M. Xiang, M. Chen, D. Wang, Z. Luo, Deep reinforcement learning-based load balancing strategy for multiple controllers in SDN. *e-Prime - Advanced in Electrical Engineering, Electronics and Energy*. 2. art. 100038, 1–9, 2022. <https://doi.org/10.1016/j.prime.2022.100038>
- 347.J. Xie, D. Guo, Z. Hu, T. Qu, P. Lv, Control plane of software defined networks: a survey. *Computer*

- Communications, 67, 1–10, 2015. <https://doi.org/10.1016/j.comcom.2015.06.004>
- 348.L. Xue, C. Cao, Research on distributed UWSN power control algorithm based on cooperative game. *Peer-to-Peer Networking and Applications*, 18, art. 96, 1–12, 2025. <https://doi.org/10.1007/s12083-024-01897-3>
- 349.R.N. Yadav, R. Misra, Approximating the largest connected topology in cognitive radio networks. *Comp. Commun.*, 142, 49–63, 2018. <https://doi.org/10.1016/j.comnet.2018.06.005>
- 350.R.N. Yadav, R. Misra, Approximating common control channel problem in cognitive radio networks. *IEEE Systems J.*, 13(1), 301–312, 2019. <http://doi.org/10.1109/JSYST.2018.2824544>
- 351.H. Yaman, *Concentrator Location in Telecommunications Networks*. Springer, 2005. ISBN: 978-0-387-23531-8
- 352.H. Yaman, Concentrator location in telecommunication networks. *4OR*, 2(2), 175–177, 2004. <https://doi.org/10.1007/s10288-003-0030-6>
- 353.S.-H. Yang, *Wireless Sensor Networks. Principles, Design and Applications*. Springer, 2014. <https://doi.org/10.1007/978-1-4471-5505-8>
- 354.K. Yang, D. Guo, B. Zhang, B. Zhao, Multi-controller placement for load balancing in SDWAN. *IEEE Access*, 7, 167278–167289, 2019. <https://doi.org/10.1109/ACCESS.2019.2953723>
- 355.G. Yao, J. Bi, Y. Li, L. Guo, On the capacitated controller placement problem in software defined networks. *IEEE Commun. Lett.*, 18(8), 1339–1342, 2014. <https://doi.org/10.1109/LCOMM.2014.2332341>
- 356.M. Younis, K. Akkaya, Strategies and techniques for node placement in wireless sensor networks: A survey *Ad Hoc Networks*, 6(4), 621–655, 2008. <https://doi.org/10.1016/j.adhoc.2007.05.003>
- 357.M.S. Yousefpoor, H. Barati, Dynamic key management algorithms in wireless sensor network: a survey. *Computer Communications*, 134, 52–69, 2019. <https://doi.org/10.1016/j.comcom.2018.11.005>
- 358.B. Yuan, H. Chen, X. Yao, Optimal relay placement for lifetime maximization in wireless underground sensor networks. *Inform. Sci.*, 418–419, 463–479, 2017. <https://doi.org/10.1016/j.ins.2017.08.018>
- 359.T. Yuan, X. Huang, M. Ma, J. Yuan, Balance-based SDN controller placement and assignment with minimum weight matching. In: *Proc. of the 2018 Int. Conf. on Communications (ICC)*, pp. 1–6, 2018. <https://doi.org/10.1109/ICC.2018.8422637>
- 360.T. Yuan, W.d.R. Neto, C.E. Rothenberg, K. Obraczka, C. Barakat, T. Turletti, Dynamic controller assignment in software defined internet of vehicles through multi-agent deep reinforcement learning. *IEEE Trans. on Network and Service Management*, 18(1), 585–596, 2021. <https://doi.org/10.1109/TNSM.2020.3047765>
- 361.A. Yuskov, I. Kulachenko, A. Melnikov, Y. Kochetov, Stadium antennas deployment optimization. In: A. Ereemeev, M. Khachay, Y. Kochetov, V. Mazalov, P. Pardalos (eds), *Proc. 23rd Int. Conf. Mathematical Optimization Theory and Operations Research MOTOR 2024*, LNCS, Springer, pp. 449–461, 2024. <https://doi.org/10.1007/978-3-031-62792-7>
- 362.M.N. Yusuf, K.B.A. Bakar, B. Isyaku, F. Mukhlif, Distributed controller placement in software-defined networks with consistency and interoperability problems. *J. of Electrical and Computer Engineering*, art. ID 6466996, 1–33, 2023. <https://doi.org/10.1155/2023/6466996>
- 363.A. Zahmatkesh, C.-H. Lung, Using heuristics to the controller placement problem in software-defined multihop wireless networking. *Communications and Network*, 12, 199–219, 2022. <https://doi.org/10.4236/cn.2020.124010>
- 364.A. Zahmatkesh, C.-H. Lung, Deep reinforcement learning for cost-effective controller placement in software-defined multihop wireless networking. In: E. Renault, S. Boumerdassi, P. Muhlethaler (eds), *Machine Learning for Networking MLN 2021*, LNCS 13175, Springer, pp. 131–147, 2022. <https://doi.org/10.1007/978-3-030-98978-1>
- 365.A. Zahmatkesh, C.-H. Lung, T. Kunz, Controller placement in software-defined multi-hop wireless networks: optimal solution and GA-based approximation. *Mobile Networks and Applications*, 27, 1311–1326, 2022. <https://doi.org/10.1007/s11036-021-01894-3>
- 366.P. Zeng, Z. Wang, Z. Jia, L. Kong, D. Li, X. Jin, Time-slotted software-defined Industrial Ethernet for real-time Quality of Service in Industry 4.0. *FGCS*, 99, 11–26, 2019. <https://doi.org/10.1016/j.future.2019.04.009>
- 367.W. Zhang, M.S. Bransky, S.M. Phillips, Stability of networked control systems. *IEEE Control Systems Magazine*, 21(1), 84–99, 2001. <https://doi.org/10.1109/37.898794>

- 368.Y. Zhang, N. Beheshti, M. Tatipamula, On resilience of split-architecture networks. In: Global Telecommunications Conf. GLOBECOM 2011, pp. 1-6, 2011. <https://doi.org/10.1109/GLOCOM.2011.6134496>
- 369.T. Zhang, P. Giaccone, A. Bianco, S. De Domenico, The role of the inter-controller consensus in the placement of distributed SDN controllers. *Computer Communications*, 113, 1–13, 2017. <https://doi.org/10.1016/j.comcom.2017.09.007>
- 370.B. Zhang, X. Wang, M. Huang, Multi-objective optimization controller placement problem in Internet-oriented software defined network. *Computer Commun.*, 123, 24–35, 2018. <https://doi.org/10.1016/j.comcom.2018.04.008>
- 371.Y. Zhang, L. Cui, W. Wang, Y. Zhahng, A survey on software defined networking with multiple controllers. *J. of Netw. and Comp. Appl.*, 103, 101–118, 2018. <https://doi.org/10.1016/j.jnca.2017.11.015>
- 372.Y. Zhang, Y. Zhou, Distributed coordination control of traffic network flow using adaptive genetic algorithm based on cloud computing. *J. of Netw. and Comp. Appl.*, 119, 110–120, 2018. <https://doi.org/10.1016/j.jnca.2018.07.001>
- 373.L. Zhang, F. Yang, Y. Lei, Tree-based intermittent connection fault diagnosis for controller area network. *IEEE Trans. on Vehicular Technology*, 68(9), 9151–9161, 2019. <https://doi.org/10.1109/TVT.2019.2929419>
- 374.Y. Zhang, H. Zhou, J.-I. Chen, Cross-layer access control in publish/subscribe middleware over software-defined networks. *Computer Communications*, 134, 1–13, Jan. 2019. <https://doi.org/10.1016/j.comcom.2018.11.001>
- 375.X.-M. Zhang, Q.-L. Han, X. Ge, D. Ding, L. Ding, D. Yue, C. Peng, Networked control systems: a survey of trends and techniques. *IEEE/CAA J. of Automatica Sinica*, 7(1), 1–17, 2020. <https://doi.org/10.1109/JAS.2019.1911651>
- 376.Y. Zhang, L. Dai, On the optimal placement of base station antennas for distributed antenna systems. *IEEE Commun. Lett.*, 24(12), 2878–2882, 2020. <https://doi.org/10.1109/LCOMM.2020.3020373>
- 377.Z. Zhao, P. Cumino, C. Esposito, M. Xiao, D. Rosario, T. Braun, E. Cerqueira, S. Sargento, Smart unmanned aerial vehicles as base stations placement to improve the mobile network operations. *Computer Communications*, 181, 45–57, 2022. <https://doi.org/10.1016/j.comcom.2021.09.016>
- 378.Q. Zheng, R. Li, X. Li, N. Shah, J. Zhang, F. Tian, K.-M. Chao, J. Li, Virtual machine consolidated placement based on multiobjective biogeography-based optimization. *FGCS*, 54, 95-122, 2016. <https://doi.org/10.1016/j.future.2015.02.010>
- 379.Q. Zhong, Y. Wang, W. Li, X. Qiu, A min-cover based controller placement approach to build reliable control network in SDN. In: *Proc. IEEE/IFIP Netw. Oper. Manage. Symp. (NOMS)*, pp. 481–487, 2016. <https://doi.org/10.1109/NOMS.2016.7502847>
- 380.P. Zhou, X. Wang, B.S. Manoj, R. Rao, On optimizing gateway placement for throughput in wireless mesh networks. *EURASIP J. on Wir. Commun. Netw.*, art. ID 368423, 1–12, 2010. <https://doi.org/10.1155/2010/368423>
- 381.L. Zhu, R. Chai, Q. Chen, Control plane delay minimization based SDN controller placement scheme. In: *2007 9th Int. Conf. on Wireless Communications and Signal Processing (WCSP)*, pp. 1–6, 2017. <https://doi.org/10.1109/WCSP.2017.8171153>
- 382.F. Zobary, Optimizing SDN controller to switch latency for controller placement problem. *Informatica*, 48, 165-176 2024. <https://doi.org/10.31449/inf.v48i8.5846>
- 383.C. Zopounidis, M. Doumpos, Multicriteria classification and sorting methods: a literature review. *EJOR*, 138(2), 229-246, 2002. [https://doi.org/10.1016/S0377-2217\(01\)00243-0](https://doi.org/10.1016/S0377-2217(01)00243-0)

Author work address: Mark Sh. Levin, Kharkevich Inst. for Information Transmission Problem, Russian Academy of Sciences, 19 Bolshoy Karetny lane, Moscow 127051, Russia

Author home address: Mark Sh. Levin, Sumskey Proezd 5-1-103, Moscow 117208, Russia
<http://www.mslevin.iitp.ru/> email: mslevin@acm.org